

# REFERENCE GUIDE



> Inductive  
Proximity



# DATALOGIC: SOLUTIONS FOR INDUSTRIAL AUTOMATION

Datalogic Industrial Automation is an industry-leader in products and solutions for material handling, traceability, inspection and detection applications.

With the acquisitions of Accu-Sort and PPT Vision in 2012, the company offers a comprehensive portfolio of products, technologies and solutions delivered by a team of skilled professionals dedicated in providing superior service to customers.

Datalogic is the partner of choice for organizations in the Industrial Automation market.

## Factory Automation

- AUTOMOTIVE
- ELECTRONICS
- FOOD & BEVERAGE
- GENERAL MANUFACTURING
- HEALTHCARE - PHARMACEUTICAL

## Transportation & Logistics

- AIRPORTS
- COURIER, EXPRESS PARCEL (CEP)
- POSTAL
- RETAIL DISTRIBUTION

## Product portfolio

Datalogic Industrial Automation has the most comprehensive offering of products and solutions for traceability, inspection and detection applications in factory automation and logistics processes: industrial LASER scanners, cameras and vision systems, sensors, machine safety devices and LASER markers.

## Identification

Even the most demanding and efficient automation of identification processes can leverage Datalogic Industrial Automation's leadership in the market. We manufacture the world's most comprehensive family of fixed-mount line and omnidirectional scanners.

We also offer the latest CCD vision technology with the world's largest installed base of CCD systems for bar code reading and dimensioning.

All of our AUTO-ID products and solutions leverage the broadest decoding library that has been developed through the years. Datalogic's comprehensive AUTO-ID portfolio is used in a wide range of applications and machines which are behind many of the everyday processes that keeps the global economy running.

## Sensors & Safety

Datalogic Industrial Automation offers a best-in-class, comprehensive product portfolio of photoelectric and proximity sensors, rotary encoders, temperature controllers and measurement devices, as well as type 2 and type 4 safety light curtains.

These product lines provide solutions for applications involving color, contrast and luminescence, label detection, dimensional and distance measurement, in addition to machine safeguarding and access control in dangerous areas.

## Machine Vision

The Datalogic Industrial Automation machine vision product line encompasses both hardware and software while covering a wide range of performance and price point requirements. The vision portfolio of products and solutions ranges from simple vision sensors to smart cameras and embedded vision systems.

## Laser Marking

Laser Marking sources and systems provide value driven marking solutions for automotive, metal tools, medical, electronics and packaging. Datalogic Industrial Automation offers an extensive range of state-of-the-art technology, excellent performance and high reliability marking equipment.



## Inductive Sensors

Inductive proximity sensors generate a magnetic field from their detection faces. Whenever a detectable object moves into the sensor's field of detection, Eddy currents build up in the target and dampen the sensor's magnetic field. This effect triggers the sensor's output. Since a current in the target is needed for detection, inductive proximity sensors are uniquely suited for detection of all types of metals.

### ADVANTAGES

- Not affected by humidity and dust
- No moving parts, no mechanical wear
- Independent of the color of the object to detect
- No dead zone

### DISADVANTAGES

- only detect metallic objects
- low operating distance
- sensitive to electromagnetic interference (such as electric welding, induction ovens)

### Shielded models - FLUSH mounting

Shielded models can be installed with their sensing faces flush to the metal. The distance from opposing metal surfaces must be  $\geq 3s_n$  and the distance between two proximity switches (side-by-side)  $\geq 2D$ .

### Unshielded models - NON-FLUSH mounting

Unshielded models can be identified by their 'caps', since they have no metal housing surrounding the area of the sensing face. The sensing face must extend  $\geq 2s_n$  from the metallic installation medium. The distance from opposing metal surfaces must be  $\geq 3s_n$  and the distance between two adjacent proximity switches  $\geq 3D$ . The metal body leaves uncovered part of the sensing area resulting in an increased sensing distance.

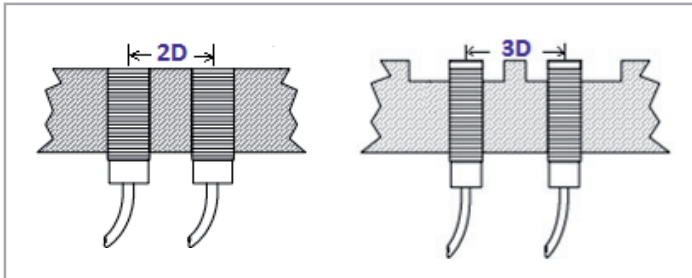

Main tubular models are available in both nickel plated brass and stainless steel housing, with the active sensing face in LCP plastic.

### METAL FACE version:

Are available stainless steel versions (M12, M18). Are used in especially harsh environments and applications which are too extreme for standard sensors. They resist to abrasive media, aggressive cleaners and solvents with their rugged sensing face. IP67 protection.

### WELD FIELD IMMUNE version:

These special field immune models are ideal for welding environments and other applications where large magnetic fields are present. They are rated for reliable operation near the current line carrying 20,000 amps.

### NAMUR version:

Are available 2 wires versions (M5, M6,5, M8, M12, M18, M30). They can be used in conjunction with suitable switching amplifiers, in explosive systems or Zone 1 and Zone 2 areas. The switch amplifier must be installed outside the explosive area. Almost all versions have IP67 mechanical protection.

Nominal Switching distance ( $s_n$ ) According to EN 60947-5-2

When an inductive proximity sensor is rated for sensing distance, it refers to the sensor's ability to detect the 'standard detectable object' at its specified sensing distance. The 'standard detectable object' is a 1mm thick square piece of ferrous iron that is in height and width the size of the proximity sensor's detection face's diameter.

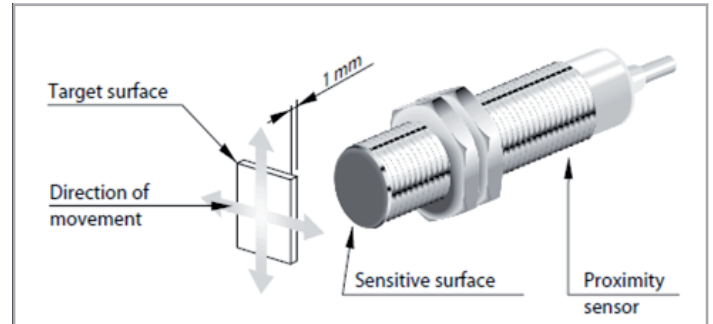

When the object to be detected is a different metal material, multiply the value of the rated operating distance for a reduction factor. The table beside shows the reduction factors of the main metals used in industry.

REDUCING FACTOR	
Fe37	1 x $s_n^*$
Stainless-steel	0,9 x $s_n$
Brass-Bronze	0,5 x $s_n$
Alluminium	0,4 x $s_n$
Copper	0,3 x $s_n$

### Hysteresis (H):

distance between the point of switching on and the point of switching off of the trigger object. The value is a percentage of the nominal switching distance  $s_n$ .

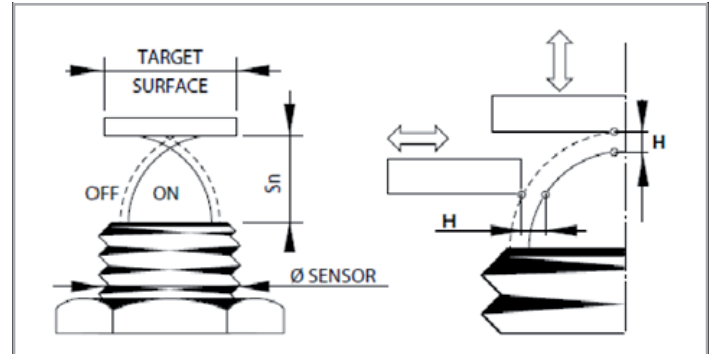

### AC/DC version:

Are available 2/3-wires versions (M12, M18, M30), that operate in alternating current with voltage drop of 5 V for currents of the order of 100mA. To be able to provide a proper potential drop at the load, it is recommended to power the sensors with at least a supply voltage equal to the Voltage drop indicated (5V).

"M12/18/30 models are Diversy and ECOLAB tested"



M12/18/30 FLUSH models are ATEX certified  
I I 3G EX nA II T6  
I I 3D EX tD A22 IP67 T85°C



## OPERATING DISTANCE

MODEL	M4	M5	M6,5	M8	M12	M18	M30	SQUARE
DIAMETER (mm)	4	5	6,5	8	12	18	30	8X8; 40X40
OPERATING DISTANCE (mm)	0,8	0,8...1,5	1...3	1,5...3	2...8	5...14	10...20	1,5...30

## HOUSING LENGTHS

The following table shows the approximate length (mm) intervals for all categories and models of tubular inductive sensors.

MODELS	STANDARD		SHORT	
	connector	cable	connector	cable
M4	---	25	---	---
M5	40	20...25	---	---
M6,5	53...63	46...55	50...54	40...44
M8	52...73	44...55	48...57	40...44
M12	68...72	58...64	48...54	42...48
M18	73...82	70...78	56...65	47...56
M30	74...85	70...82	56...68	49...56

## WIRES

TYPE	description
2-3 WIRES	Work with sinking or sourcing devices
	Vdc, Vac and NAMUR versions
	Higher leakage current
3 WIRES	Must select PNP or NPN, NC or NO version
	10-30 Vdc version
	Low leakage current
4 WIRES	Programmable output
	PNP/NPN and NC/NO in one device

The number of inductive proximity sensors that can be connected in series or parallel is limited.

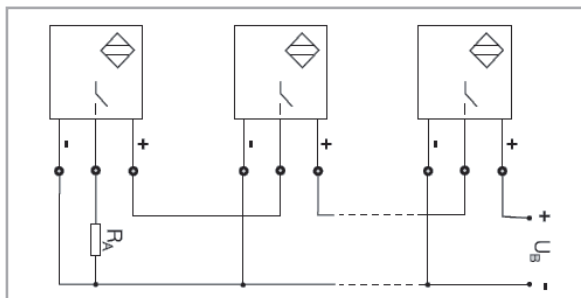

Parallel connection: the leakage current of each single sensor, when added to the other, may accumulate and drive the load even in the absence of operated switches.

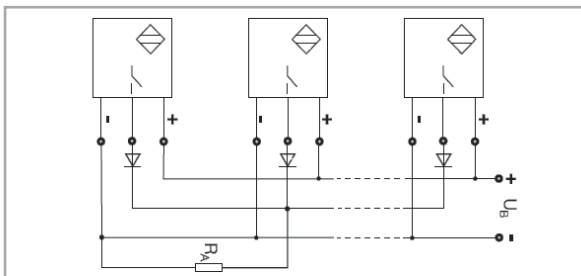

This problem is more relevant in versions AC 2-wire, because of the high voltages and currents supplied to the sensor. For this type of connection you should use a 3-wire sensors working in DC.

## ELECTRICAL PARAMETERS

- NOMINAL VOLTAGE**  
 Is the permissible voltage range in which certain safe operation of the switch is guaranteed.
- RESIDUAL RIPPLE**  
 Is the maximum admissible ripple of the DC supply voltage shown as percentage to its medium value.
- MAX. OUTPUT CURRENT**  
 It shows maximum output current a sensor can cope with when working steadily.
- MIN. OUTPUT CURRENT**  
 Is the smallest load current required for function of the switch when ON.
- RESIDUAL CURRENT**  
 Is the current flowing through the load when a proximity switch is not conducting (open).
- VOLTAGE DROP**  
 Is the voltage measured across the load of a closed (conducting) sensor at load current.
- START UP DELAY**  
 Is the time from when the supply voltage is applied, and the proximity switch assumes the ready state. This time may not be longer than 300 ms. During this time there must be no fault signal longer than 2 ms.
- SWITCHING FREQUENCY**  
 Refers to the maximum number of switching operations per second.
- SHORT CIRCUIT PROTECTION**  
 Is 100 A, i. e., per EN 60947-5-2 the power supply during testing in short circuit mode must be able to provide at least 100 A for a short duration. This current is prescribed in the standard in order to test.
- PROTECTION AGAINST INVERSION OF POLARITY**  
 Available in DC supplied type, it prevents the sensor from being damage when supply cables are incorrectly connected.
- INDUCTIVE LOAD PROTECTION**  
 It protects sensor output in presence of high inductive loads. This protection is performed by a diode or zener diode.

## BASIC

08

- Nickel-plated Brass housing
- Standard length
- Short length
- Normal and Double range Operating distance
- Operating distance: 1,5 ... 20 mm
- M6,5, M8, M12, M18, M30
- cable, M8 or M12 connector
- 2, 3 or 4 wires
- PNP, NPN, PNP/NPN, NO, NC, NO/NC
- IP67 protection

## STAINLESS STEEL

32

- Stainless Steel housing
- Standard length
- Short length
- Normal and Double range Operating distance
- Operating distance 0.8 ... 20 mm
- M4, M5, M6,5, M8, M12, M18, M30
- cable, M8 or M12 connector
- 3 wires
- PNP, NPN, NO, NC
- IP67 protection

## INDUCTIVE AC

54

- Nickel-plated Brass housing
- Standard length
- Operating distance 2 ... 10 mm
- M12, M18, M30
- cable or M12 connector
- 20+250 Vac (50,60 Hz)
- 2 or 3 wires
- NO
- IP67 protection

## NAMUR

60

- Stainless Steel housing
- Short length
- Operating distance 0.8 ... 15 mm
- M12, M18
- cable, M8 or M12 connector
- 2 wires
- PNP, NO
- IP67 protection

### M4

- flush
- Stainless Steel
- op.dist.: 0,8 mm
- diameter: 4 mm
- 3 wires
- PNP or NPN, N.O.
- cable

### M5

- flush
- Stainless Steel
- op.dist.: 0,8 mm
- double range vers.: 1,5 mm
- diameter: 5 mm
- 3 wires
- NAMUR vers.
- PNP or NPN, N.O., N.C.
- M8 connector or cable

### M6,5

- flush, non-flush
- Stainless Steel, Nickel plated-Brass
- op.dist.: 1,5...2 mm
- double range vers.: 2...3 mm
- diameter: 6,5 mm
- standard or short housing
- 3 wires
- NAMUR (2wires) vers.
- PNP or NPN, N.O., N.C.
- M8 connector or cable

### M8

- flush, non-flush
- Stainless Steel, Nickel plated-Brass
- op.dist.: 1,5...2 mm
- double range vers.: 2...3 mm
- diameter: 8 mm
- standard or short housing
- 3 wires
- NAMUR (2wires) vers.
- PNP or NPN, N.O., N.C.
- M8, M12 connector or cable

### M12

- flush, non-flush
- Stainless Steel, Nickel plated-Brass
- op.dist.: 2...4 mm
- double range vers.: 4...8 mm
- diameter: 12 mm
- standard or short housing
- 2, 3, 4 (programmable NPN/PNP output) wires
- Vac/Vdc vers.
- Metal Face vers.
- NAMUR vers.
- Field Immune vers.
- PNP or NPN, N.O., N.C.
- M12 connector or cable

## METAL FACE

46

- Stainless Steel housing
- Stainless Steel active face
- Standard length
- 2 ... 8 mm
- M12, M18
- M12 connector
- 3 wires
- PNP, NO
- IP67 protection

## WELD FIELD IMMUNE

50

- Stainless Steel housing
- PTFE active face
- Standard length
- Operating distance 2 ... 8 mm
- M12, M18
- M12 connector
- 3 wires
- PNP, NO
- IP67 protection

pag

08

BASIC

pag

32

STAINLESS  
STEEL

pag

46

METAL  
FACE

pag

50

WELD FIELD  
IMMUNE

## SQUARE

70

- PBT (resin) or Nickel-plated Brass housing
- Operating distance 1.5 ... 15 mm
- 40x40 mm or 8x8 mm dimension
- cable, M8 connector or Terminal Block
- 2 or 3 wires
- PNP, PNP/NPN, NO, NC, NO/NC
- IP67

## CABLES, CONNECTORS & ACCESSORIES

76

- 2,3,4 wires
- M12, M8 connector
- axial or radial 90°
- shielded or unshielded
- double key
- A.C. cable
- 3, 5, 7, 10, 15, 25m cable

pag

54

INDUCTIVE AC

pag

60

NAMUR

pag

70

SQUARE

pag

76

CABLES,  
CONNECTORS  
& ACCESSORIES

### M18

- flush, non-flush
- Stainless Steel, Nickel plated-Brass
- op.dist.: 5...8 mm
- double range vers.: 8...14 mm
- diameter: 18 mm
- standard or short housing
- 2, 3, 4 (programmable NPN/PNP output) wires
- Vac/Vdc vers.
- Metal Face vers.
- Field Immune vers.
- NAMUR vers.
- PNP or NPN, N.O., N.C.
- M12 connector or cable

### M30

- flush, non-flush
- Stainless Steel, Nickel plated-Brass
- op.dist.: 10...15 mm
- double range vers.: 15...20 mm
- diameter: 30 mm
- standard or short housing
- 2, 3, 4 (programmable NPN/PNP output) wires
- Vac/Vdc vers.
- NAMUR vers.
- PNP or NPN, N.O., N.C.
- M12 connector or cable

### SQUARE 40X40

- flush, non-flush
- standard or short housing
- Plastic (PBT resin)
- op.dist.: 15...30 mm; 7-20 mm (Analog vers.)
- diameter: 40 mm
- 2, 3 wires
- Vac/Vdc vers.
- Analog output 4-20mA vers.
- PNP or NPN, N.O., N.C.
- Terminal block

### SQUARE 8X8

- flush
- Nickel-Plated Brass
- op.dist.: 1,5 mm
- diameter: 8 mm
- 3 wires, PNP, N.O.
- M8 connector or cable

# BASIC

Nickel-plated Brass housing

Standard length

Short length

Normal and double range operating distance

Operating distance: 1,5 ... 20 mm

M6,5, M8, M12, M18, M30

cable, M8 or M12 connector

2, 3 or 4 wires

PNP, NPN, PNP/NPN, NO, NC, NO/NC

IP67 protection

“M12/18/30 모델은 Diversey & ECOLAB 테스트(세제에 대한 부식)를 거친 제품입니다”



M12/18/30 FLUSH models are ATEX certified

II 3G EX nA II T6

II 3D EX tD A22 IP67 T85°C



pag  
08

BASIC

pag  
32

STAINLESS  
STEEL

pag  
46

METAL  
FACE

pag  
50

WELD FIELD  
IMMUNE

pag  
54

INDUCTIVE AC

pag  
60

NAMUR

pag  
70

SQUARE

pag  
76

CABLES,  
CONNECTORS  
& ACCESSORIES



# BASIC

# BASIC M6.5

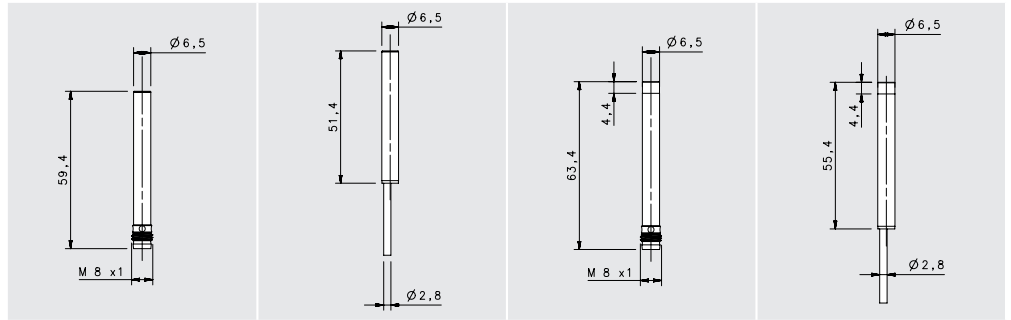

## STANDARD

				FLUSH		NON FLUSH	
				M8 conn	cable	M8 conn	cable
NOMINAL SWITCHING DISTANCE				1,5 mm	1,5 mm	2 mm	2 mm
10-30 Vdc	PNP/NPN NO-NC	4 wires	order No.	---	---	---	---
10-30 Vdc	PNP NO	3 wires	order No.	IS-65-A1-S1 95B066050	IS-65-A1-03 95B064730	IS-65-C1-S1 95B066210	IS-65-C1-03 95B064890
10-30 Vdc	PNP NC	3 wires	order No.	IS-65-A2-S1 95B066090	IS-65-A2-03 95B064770	IS-65-C2-S1 95B066250	IS-65-C2-03 95B066300
10-30 Vdc	NPN NO	3 wires	order No.	IS-65-A3-S1 95B064970	IS-65-A3-03 95B064650	IS-65-C3-S1 95B066130	IS-65-C3-03 95B064810
10-30 Vdc	NPN NC	3 wires	order No.	IS-65-A4-S1 95B066010	IS-65-A4-03 95B064690	IS-65-C4-S1 95B066170	IS-65-C4-03 95B064850
10-30 Vdc	PNP NO-NC	3 wires	order No.	---	---	---	---
10-30 Vdc	NPN NO-NC	3 wires	order No.	---	---	---	---
10-30 Vdc	NO-NC	2 wires	order No.	---	---	---	---
20-250 Vac/Vdc	NO	2 wires	order No.	---	---	---	---
20-250 Vac/Vdc	NC	2 wires	order No.	---	---	---	---
20-250 Vac/Vdc	NO	2/3wires	order No.	---	---	---	---
Analog 0-20 mA	-	3 wires	order No.	---	---	---	---
5+24 Vdc	NAMUR	2 wires	order No.	---	---	---	---

	10-30 Vdc (-15/10%)	10-30 Vdc (-15/10%)	10-30 Vdc (-15/10%)	10-30 Vdc (-15/10%)
Nominal Voltage	10-30 Vdc (-15/10%)	10-30 Vdc (-15/10%)	10-30 Vdc (-15/10%)	10-30 Vdc (-15/10%)
Residual Ripple	< 10%	< 10%	< 10%	< 10%
Hysteresis	< 10%	< 10%	< 10%	< 10%
Max. Output Current	200 mm	200 mA	200 mm	200 mA
Min. Output Current	---	---	---	---
Residual Current	< 1,6 mA	< 1,6 mA	< 1,6 mA	< 1,6 mA
Voltage Drop	< 1,2 V (I=100 mA)	< 1,2 V (I=100 mA)	< 1,2 V (I=100 mA)	< 1,2 V (I=100 mA)
Operation Led	Yellow	Yellow	Yellow	Yellow
Switching Frequency	1000 Hz	1000 Hz	1000 Hz	1000 Hz
Start Up Delay	< 50 ms	< 50 ms	< 50 ms	< 50 ms
Repeability	< 3%	< 3%	< 3%	< 3%
Short Circuit Protection	Present (self-resetting)	Present (self-resetting)	Present (self-resetting)	Present (self-resetting)
Electric Protection	Against polarity reversal inductive loads	Against polarity reversal inductive loads	Against polarity reversal inductive loads	Against polarity reversal inductive loads
Temperature Limit	(-25 ... +70 °C)	(-25 ... +70 °C)	(-25 ... +70 °C)	(-25 ... +70 °C)
Protection Degree	IP67	IP67	IP67	IP67
Cable Length	---	2 m	---	2 m
Cable Section	---	3x 0,14 mm <sup>2</sup>	---	3x 0,14 mm <sup>2</sup>
Housing Material	Nickel-plated brass	Nickel-plated brass	Nickel-plated brass	Nickel-plated brass
Weight - Cable Output	---	80 g	---	80 g
Weight - M12 Connector Output	40 g	---	40 g	---



# BASIC M6.5

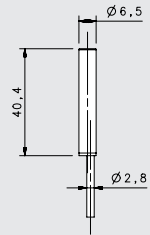
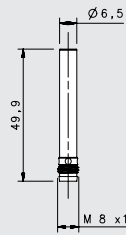

## SHORT X2

FLUSH

M8 conn

cable

2 mm

2 mm

### NOMINAL SWITCHING DISTANCE

				M8 conn	cable
				2 mm	2 mm
10-30 Vdc	PNP/NPN NO-NC	4 wires	order No.	---	---
10-30 Vdc	PNP NO	3 wires	order No.	IS-65-G1-S1 95B066060	IS-65-G1-03 95B064740
10-30 Vdc	PNP NC	3 wires	order No.	IS-65-G2-S1 95B066100	IS-65-G2-03 95B064780
10-30 Vdc	NPN NO	3 wires	order No.	IS-65-G3-S1 95B064980	IS-65-G3-03 95B064660
10-30 Vdc	NPN NC	3 wires	order No.	IS-65-G4-S1 95B066020	IS-65-G4-03 95B064700
10-30 Vdc	PNP NO-NC	3 wires	order No.	---	---
10-30 Vdc	NPN NO-NC	3 wires	order No.	---	---
10-30 Vdc	NO-NC	2 wires	order No.	---	---
20-250 Vac/Vdc	NO	2 wires	order No.	---	---
20-250 Vac/Vdc	NC	2 wires	order No.	---	---
20-250 Vac/Vdc	NO	2/3wires	order No.	---	---
Analog 0-20 mA	-	3 wires	order No.	---	---
5+24 Vdc	NAMUR	2 wires	order No.	---	---

	10-30 Vdc (-15/10%)	10-30 Vdc (-15/10%)
Nominal Voltage	10-30 Vdc (-15/10%)	10-30 Vdc (-15/10%)
Residual Ripple	< 10%	< 10%
Hysteresis	< 10%	< 10%
Max. Output Current	200 mA	200 mA
Min. Output Current	---	---
Residual Current	< 10 mA	< 10 mA
Voltage Drop	< 1,2 V (I=100mA)	< 1,2 V (I=100mA)
Operation Led	Yellow	Yellow
Switching Frequency	500 Hz	500 Hz
Start Up Delay	< 75 ms	< 75 ms
Repeability	< 3%	< 3%
Short Circuit Protection	Present (self-resetting)	Present (self-resetting)
Electric Protection	Against polarity reversal inductive loads	Against polarity reversal inductive loads
Temperature Limit	(-25 ... +70 °C)	(-25 ... +70 °C)
Protection Degree	IP67	IP67
Cable Length	---	2 m
Cable Section	---	3 x 0,14 mm <sup>2</sup>
Housing Material	Nickel-plated brass	Nickel-plated brass
Weight - Cable Output	---	80 g
Weight - M12 Connector Output	40 g	---



# BASIC M8

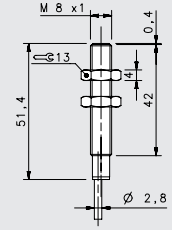
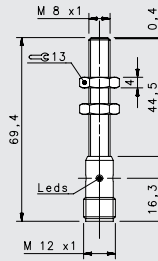
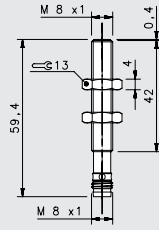

## STANDARD

### FLUSH

#### NOMINAL SWITCHING DISTANCE

				M8 conn	M12 conn	cable
				1,5 mm	1,5 mm	1,5 mm
10-30 Vdc	PNP/NPN NO-NC	4 wires	order No.	---	---	---
10-30 Vdc	PNP NO	3 wires	order No.	IS-08-A1-S1 95B061141	IS-08-A1-S2 95B061131	IS-08-A1-03 95B061121
10-30 Vdc	PNP NC	3 wires	order No.	IS-08-A2-S1 95B061171	IS-08-A2-S2 95B061161	IS-08-A2-03 95B061151
10-30 Vdc	NPN NO	3 wires	order No.	IS-08-A3-S1 95B061081	IS-08-A3-S2 95B061071	IS-08-A3-03 95B061061
10-30 Vdc	NPN NC	3 wires	order No.	IS-08-A4-S1 95B061111	IS-08-A4-S2 95B061101	IS-08-A4-03 95B061091
10-30 Vdc	PNP NO-NC	3 wires	order No.	---	---	---
10-30 Vdc	NPN NO-NC	3 wires	order No.	---	---	---
10-30 Vdc	NO-NC	2 wires	order No.	---	---	---
20-250 Vac/Vdc	NO	2 wires	order No.	---	---	---
20-250 Vac/Vdc	NC	2 wires	order No.	---	---	---
20-250 Vac/Vdc	NO	2/3 wires	order No.	---	---	---
Analog 0-20mA	-	3 wires	order No.	---	---	---
5+24 Vdc	NAMUR	2 wires	order No.	---	---	---

	10-30 Vdc (-15/10%)	10-30 Vdc (-15/10%)	10-30 Vdc (-15/10%)
Nominal Voltage	10-30 Vdc (-15/10%)	10-30 Vdc (-15/10%)	10-30 Vdc (-15/10%)
Residual Ripple	< 10%	< 10%	< 10%
Hysteresis	< 10%	< 10%	< 10%
Max. Output Current	200mA	200mA	200mA
Min. Output Current	---	---	---
Residual Current	< 10 mA	< 10 mA	< 10 mA
Voltage Drop	< 1,2 V (I=100mA)	< 1,2 V (I=100mA)	< 1,2 V (I=100mA)
Operation Led	Yellow	Yellow	Yellow
Switching Frequency	1000 Hz	1000 Hz	1000 Hz
Start Up Delay	< 50 ms	< 50 ms	< 50 ms
Repeability	< 3%	< 3%	< 3%
Short Circuit Protection	Present (self-resetting)	Present (self-resetting)	Present (self-resetting)
Electric Protection	Against polarity reversal inductive loads	Against polarity reversal inductive loads	Against polarity reversal inductive loads
Temperature Limit	(-25 ... +70 °C)	(-25 ... +70 °C)	(-25 ... +70 °C)
Protection Degree	IP67	IP67	IP67
Cable Length	---	---	2 m
Cable Section	---	---	3x 0,14 mm <sup>2</sup>
Housing Material	Nickel-plated brass	Nickel-plated brass	Nickel-plated brass
Weight - Cable Output	---	---	80 g
Weight - M12 Connector Output	35g	55g	---



# BASIC M8

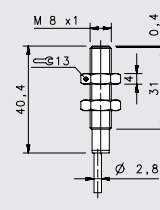
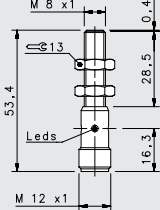
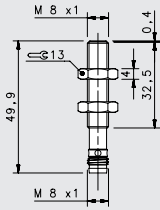

## SHORT

### FLUSH

#### NOMINAL SWITCHING DISTANCE

				M8 conn	M12 conn	cable
				1,5 mm	1,5 mm	1,5 mm
10-30 Vdc	PNP/NPN NO-NC	4 wires	order No.	---	---	---
10-30 Vdc	PNP NO	3 wires	order No.	IS-08-B1-S1 95B066860	IS-08-B1-S2 95B066590	IS-08-B1-03 95B061921
10-30 Vdc	PNP NC	3 wires	order No.	IS-08-B2-S1 95B066890	IS-08-B2-S2 95B066620	IS-08-B2-03 95B061951
10-30 Vdc	NPN NO	3 wires	order No.	IS-08-B3-S1 95B066810	IS-08-B3-S2 95B066530	IS-08-B3-03 95B061861
10-30 Vdc	NPN NC	3 wires	order No.	IS-08-B4-S1 95B066830	IS-08-B4-S2 95B066560	IS-08-B4-03 95B061891
10-30 Vdc	PNP NO-NC	3 wires	order No.	---	---	---
10-30 Vdc	NPN NO-NC	3 wires	order No.	---	---	---
10-30 Vdc	NO-NC	2 wires	order No.	---	---	---
20-250 Vac/Vdc	NO	2 wires	order No.	---	---	---
20-250 Vac/Vdc	NC	2 wires	order No.	---	---	---
20-250 Vac/Vdc	NO	2/3 wires	order No.	---	---	---
Analog 0-20mA	-	3 wires	order No.	---	---	---
5+24 Vdc	NAMUR	2 wires	order No.	---	---	---

	10-30 Vdc (-15/10%)	10-30 Vdc (-15/10%)	10-30 Vdc (-15/10%)
Nominal Voltage	10-30 Vdc (-15/10%)	10-30 Vdc (-15/10%)	10-30 Vdc (-15/10%)
Residual Ripple	< 10%	< 10%	< 10%
Hysteresis	< 10%	< 10%	< 10%
Max. Output Current	200mA	200mA	200mA
Min. Output Current	---	---	---
Residual Current	< 10 mA	< 10 mA	< 10 mA
Voltage Drop	< 1,2 V (I=100mA)	< 1,2 V (I=100mA)	< 1,2 V (I=100mA)
Operation Led	Yellow	Yellow	Yellow
Switching Frequency	1000 Hz	1000 Hz	1000 Hz
Start Up Delay	< 50 ms	< 50 ms	< 50 ms
Repeability	< 3%	< 3%	< 3%
Short Circuit Protection	Present (self-resetting)	Present (self-resetting)	Present (self-resetting)
Electric Protection	Against polarity reversal inductive loads	Against polarity reversal inductive loads	Against polarity reversal inductive loads
Temperature Limit	(-25 ... +70 °C)	(-25 ... +70 °C)	(-25 ... +70 °C)
Protection Degree	IP67	IP67	IP67
Cable Length	---	---	2 m
Cable Section	---	---	3x 0,14 mm <sup>2</sup>
Housing Material	Nickel-plated brass	Nickel-plated brass	Nickel-plated brass
Weight - Cable Output	---	---	80 g
Weight - M12 Connector Output	35g	55g	---



# BASIC M8

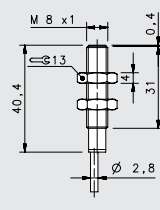
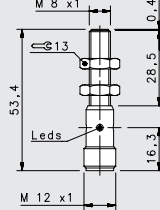
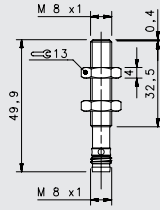

## SHORT X2

FLUSH

### NOMINAL SWITCHING DISTANCE

				M8 conn	M12 conn	cable
				2 mm	2 mm	2 mm
10-30 Vdc	PNP/NPN NO-NC	4 wires	order No.	---	---	---
10-30 Vdc	PNP NO	3 wires	order No.	IS-08-G1-S1 95B066850	IS-08-G1-S2 95B066580	IS-08-G1-O3 95B066370
10-30 Vdc	PNP NC	3 wires	order No.	IS-08-G2-S1 95B066880	IS-08-G2-S2 95B066610	IS-08-G2-O3 95B066390
10-30 Vdc	NPN NO	3 wires	order No.	IS-08-G3-S1 95B066800	IS-08-G3-S2 95B066520	IS-08-G3-O3 95B066330
10-30 Vdc	NPN NC	3 wires	order No.	IS-08-G4-S1 95B063131	IS-08-G4-S2 95B066550	IS-08-G4-O3 95B066350
10-30 Vdc	PNP NO-NC	3 wires	order No.	---	---	---
10-30 Vdc	NPN NO-NC	3 wires	order No.	---	---	---
10-30 Vdc	NO-NC	2 wires	order No.	---	---	---
20-250 Vac/Vdc	NO	2 wires	order No.	---	---	---
20-250 Vac/Vdc	NC	2 wires	order No.	---	---	---
20-250 Vac/Vdc	NO	2/3 wires	order No.	---	---	---
Analog 0-20mA	-	3 wires	order No.	---	---	---
5+24 Vdc	NAMUR	2 wires	order No.	---	---	---

	10-30 Vdc (-15/10%)	10-30 Vdc (-15/10%)	10-30 Vdc (-15/10%)
Nominal Voltage	10-30 Vdc (-15/10%)	10-30 Vdc (-15/10%)	10-30 Vdc (-15/10%)
Residual Ripple	< 10%	< 10%	< 10%
Hysteresis	< 10%	< 10%	< 10%
Max. Output Current	200mA	200mA	200mA
Min. Output Current	---	---	---
Residual Current	< 10 mA	< 10 mA	< 10 mA
Voltage Drop	< 1,2 V (I=100mA)	< 1,2 V (I=100mA)	< 1,2 V (I=100mA)
Operation Led	Yellow	Yellow	Yellow
Switching Frequency	500 Hz	500 Hz	500 Hz
Start Up Delay	< 75 ms	< 75 ms	< 75 ms
Repeability	< 3%	< 3%	< 3%
Short Circuit Protection	Present (self-resetting)	Present (self-resetting)	Present (self-resetting)
Electric Protection	Against polarity reversal inductive loads	Against polarity reversal inductive loads	Against polarity reversal inductive loads
Temperature Limit	(-25 ... +60 °C)	(-25 ... +60 °C)	(-25 ... +70 °C)
Protection Degree	IP67	IP67	IP67
Cable Length	---	---	2 m
Cable Section	---	---	3 x 0,14 mm <sup>2</sup>
Housing Material	Nickel-plated brass	Nickel-plated brass	Nickel-plated brass
Weight - Cable Output	---	---	80 g
Weight - M12 Connector Output	35g	55g	---



# BASIC M12

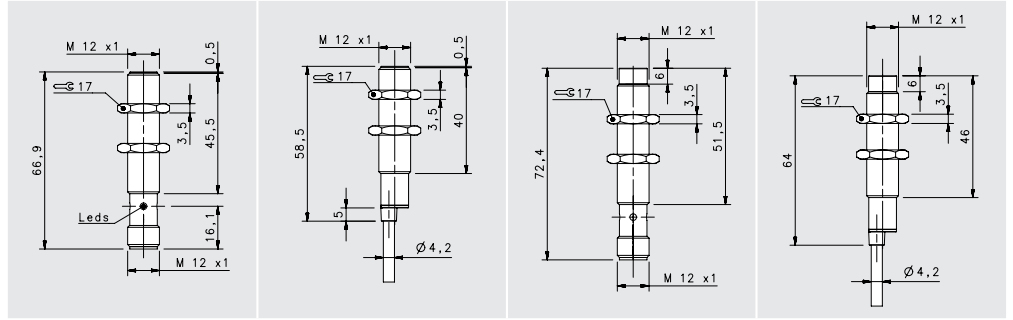

## STANDARD

### FLUSH

### NON FLUSH

M12 conn

cable

M12 conn

cable

### NOMINAL SWITCHING DISTANCE

				2 mm	2 mm	4 mm	4 mm
10-30 Vdc	PNP/NPN NO-NC	4 wires	order No.	IS-12-A0-S2 95B064060	IS-12-A0-03 95B064030	IS-12-C0-S2 95B064080	IS-12-C0-03 95B064040
10-30 Vdc	PNP NO	3 wires	order No.	IS-12-A1-S2 95B061251	IS-12-A1-03 95B061241	IS-12-C1-S2 95B061651	IS-12-C1-03 95B061641
10-30 Vdc	PNP NC	3 wires	order No.	IS-12-A2-S2 95B061281	IS-12-A2-03 95B061271	IS-12-C2-S2 95B061681	IS-12-C2-03 95B061671
10-30 Vdc	NPN NO	3 wires	order No.	IS-12-A3-S2 95B061191	IS-12-A3-03 95B061181	IS-12-C3-S2 95B061591	IS-12-C3-03 95B061581
10-30 Vdc	NPN NC	3 wires	order No.	IS-12-A4-S2 95B061221	IS-12-A4-03 95B061211	IS-12-C4-S2 95B061621	IS-12-C4-03 95B061611
10-30 Vdc	PNP NO-NC	3 wires	order No.	---	---	---	---
10-30 Vdc	NPN NO-NC	3 wires	order No.	---	---	---	---
10-30 Vdc	NO-NC	2 wires	order No.	IS-12-A9-S2 95B063931	IS-12-A9-03 95B064100	IS-12-C9-S2 95B064140	IS-12-C9-03 95B064110
20-250 Vac/Vdc	NO	2 wires	order No.	---	---	---	---
20-250 Vac/Vdc	NC	2 wires	order No.	---	---	---	---
20-250 Vac/Vdc	NO	2/3wires	order No.	---	---	---	---
Analog 0-20mA	-	3 wires	order No.	---	---	---	---
5+24 Vdc	NAMUR	2 wires	order No.	---	---	---	---

Nominal Voltage	10-30 Vdc (-15/10%)	10-30 Vdc (-15/10%)	10-30 Vdc (-15/10%)	10-30 Vdc (-15/10%)
Residual Ripple	< 10%	< 10%	< 10%	< 10%
Hysteresis	< 10%	< 10%	< 10%	< 10%
Max. Output Current	200mA; 100 mA (2wires)	200mA; 100 mA (2wires)	200mA; 100 mA (2wires)	200mA; 100 mA (2wires)
Min. Output Current	> 1,6 mA (2wires)	> 1,6 mA (2wires)	> 1,6 mA (2wires)	> 1,6 mA (2wires)
Residual Current	< 10mA; < 1,6 mA (2wires)	< 10mA; < 1,6 mA (2wires)	< 10mA; < 1,6 mA (2wires)	< 10mA; < 1,6 mA (2wires)
Voltage Drop	< 1,8V; < 6,5 V (2wires)	< 1,8V; < 6,5 V (2wires)	< 1,8V; < 6,5 V (2wires)	< 1,8V; < 6,5 V (2wires)
Operation Led	Yellow	Yellow	Yellow	Yellow
Switching Frequency	1000 Hz	1000 Hz	1000 Hz	1000 Hz
Start Up Delay	< 50 ms	< 50 ms	< 50 ms	< 50 ms
Repeability	< 3%	< 3%	< 3%	< 3%
Short Circuit Protection	Present (self-resetting)	Present (self-resetting)	Present (self-resetting)	Present (self-resetting)
Electric Protection	Against polarity reversal inductive loads	Against polarity reversal inductive loads	Against polarity reversal inductive loads	Against polarity reversal inductive loads
Temperature Limit	(-25 ... +70 °C)	(-25 ... +70 °C)	(-25 ... +70 °C)	(-25 ... +70 °C)
Protection Degree	IP67	IP67	IP67	IP67
Cable Length	---	2 m	---	2 m
Cable Section	---	2/3/4 x 0,25 mm <sup>2</sup>	---	2/3/4 x 0,25 mm <sup>2</sup>
Housing Material	Nickel-plated brass	Nickel-plated brass	Nickel-plated brass	Nickel-plated brass
Weight - Cable Output	---	110 g	---	110 g
Weight - M12 Connector Output	60 g	---	60 g	---



# BASIC M12

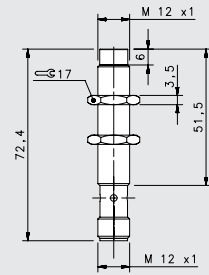
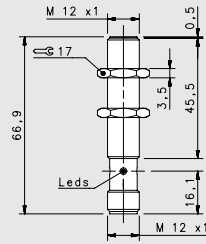

## STANDARD X2

				FLUSH	NON FLUSH
				M12 conn	M12 conn
<b>NOMINAL SWITCHING DISTANCE</b>				<b>4 mm</b>	<b>8 mm</b>
10-30 Vdc	PNP/NPN NO-NC	4 wires	order No.	---	---
10-30 Vdc	PNP NO	3 wires	order No.	IS-12-E1-S2 95B067030	IS-12-F1-S2 95B067020
10-30 Vdc	PNP NC	3 wires	order No.	---	---
10-30 Vdc	NPN NO	3 wires	order No.	---	---
10-30 Vdc	NPN NC	3 wires	order No.	---	---
10-30 Vdc	PNP NO-NC	3 wires	order No.	---	---
10-30 Vdc	NPN NO-NC	3 wires	order No.	---	---
10-30 Vdc	NO-NC	2 wires	order No.	---	---
20-250 Vac/Vdc	NO	2 wires	order No.	---	---
20-250 Vac/Vdc	NC	2 wires	order No.	---	---
20-250 Vac/Vdc	NO	2/3wires	order No.	---	---
Analog 0-20mA	-	3 wires	order No.	---	---
5+24 Vdc	NAMUR	2 wires	order No.	---	---

Nominal Voltage	10-30 Vdc (-15/10%)	10-30 Vdc (-15/10%)
Residual Ripple	< 10%	< 10%
Hysteresis	< 10%	< 10%
Max. Output Current	100 mA	100 mA
Min. Output Current	---	---
Residual Current	< 10 mA	< 10 mA
Voltage Drop	< 1,2 V (I=100mA)	< 1,2 V (I=100mA)
Operation Led	Yellow	Yellow
Switching Frequency	500 Hz	500 Hz
Start Up Delay	< 75 ms	< 75 ms
Repeability	< 3%	< 3%
Short Circuit Protection	Present (self-resetting)	Present (self-resetting)
Electric Protection	Against polarity reversal inductive loads	Against polarity reversal inductive loads
Temperature Limit	(-25 ... +70 °C)	(-25 ... +70 °C)
Protection Degree	IP67	IP67
Cable Length	---	---
Cable Section	---	---
Housing Material	Nickel-plated brass	Nickel-plated brass
Weight - Cable Output	---	---
Weight - M12 Connector Output	60 g	60 g



# BASIC M18

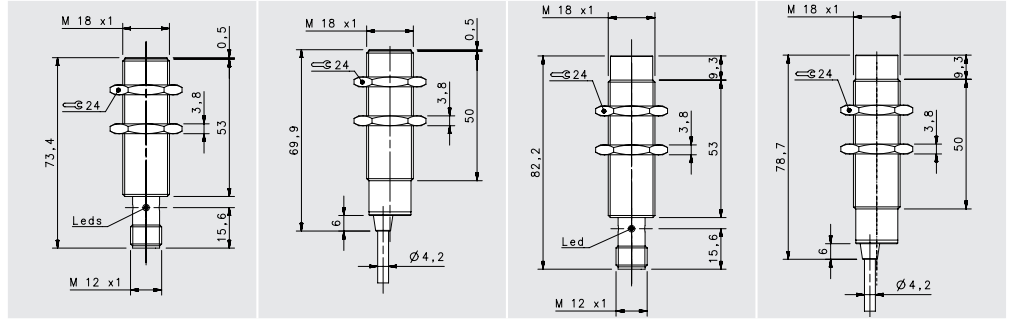

## STANDARD

				FLUSH		NON FLUSH	
				M12 conn	cable	M12 conn	cable
				5 mm	5 mm	8 mm	8 mm
NOMINAL SWITCHING DISTANCE							
10-30 Vdc	PNP/NPN NO-NC	4 wires	order No.	IS-18-A0-S2 95B064260	IS-18-A0-03 95B064230	IS-18-C0-S2 95B064280	IS-18-C0-03 95B064240
10-30 Vdc	PNP NO	3 wires	order No.	IS-18-A1-S2 95B061351	IS-18-A1-03 95B061341	IS-18-C1-S2 95B061751	IS-18-C1-03 95B061741
10-30 Vdc	PNP NC	3 wires	order No.	IS-18-A2-S2 95B061371	IS-18-A2-03 95B061361	IS-18-C2-S2 95B061771	IS-18-C2-03 95B061761
10-30 Vdc	NPN NO	3 wires	order No.	IS-18-A3-S2 95B061311	IS-18-A3-03 95B061301	IS-18-C3-S2 95B061711	IS-18-C3-03 95B061701
10-30 Vdc	NPN NC	3 wires	order No.	IS-18-A4-S2 95B061331	IS-18-A4-03 95B061321	IS-18-C4-S2 95B061731	IS-18-C4-03 95B061721
10-30 Vdc	PNP NO-NC	3 wires	order No.	---	---	---	---
10-30 Vdc	NPN NO-NC	3 wires	order No.	---	---	---	---
10-30 Vdc	NO-NC	2 wires	order No.	IS-18-A9-S2 95B063941	S-18-A9-03 95B064300	IS-18-C9-S2 95B064340	IS-18-C9-03 95B064310
20-250 Vac/Vdc	NO	2 wires	order No.	---	---	---	---
20-250 Vac/Vdc	NC	2 wires	order No.	---	---	---	---
20-250 Vac/Vdc	NO	2/3 wires	order No.	---	---	---	---
Analog 0-20mA	-	3 wires	order No.	---	---	---	---
5+24 Vdc	NAMUR	2 wires	order No.	---	---	---	---

Nominal Voltage	10-30 Vdc (-15/10%)	10-30 Vdc (-15/10%)	10-30 Vdc (-15/10%)	10-30 Vdc (-15/10%)
Residual Ripple	< 10%	< 10%	< 10%	< 10%
Hysteresis	< 10%	< 10%	< 10%	< 10%
Max. Output Current	200 mA	200 mA	200 mA	200 mA
Min. Output Current	> 1,6 mA (2wires ver.)	> 1,6 mA (2wires ver.)	> 1,6 mA (2wires ver.)	> 1,6 mA (2wires ver.)
Residual Current	< 10 mA	< 10 mA	< 10 mA	< 10 mA
Voltage Drop	< 1,8V; < 6,5 V (2wires ver.)	< 1,8V; < 6,5 V (2wires ver.)	< 1,8V; < 6,5 V (2wires ver.)	< 1,8V; < 6,5 V (2wires ver.)
Operation Led	Yellow	Yellow	Yellow	Yellow
Switching Frequency	1000 Hz	1000 Hz	1000 Hz	1000 Hz
Start Up Delay	< 50 ms	< 50 ms	< 50 ms	< 50 ms
Repeability	< 3%	< 3%	< 3%	< 3%
Short Circuit Protection	Present (self-resetting)	Present (self-resetting)	Present (self-resetting)	Present (self-resetting)
Electric Protection	Against polarity reversal inductive loads	Against polarity reversal inductive loads	Against polarity reversal inductive loads	Against polarity reversal inductive loads
Temperature Limit	(-25 ... +60 °C)	(-25 ... +60 °C)	(-25 ... +60 °C)	(-25 ... +60 °C)
Protection Degree	IP67	IP67	IP67	IP67
Cable Length	---	2 m	---	2 m
Cable Section	---	2/3/4 x 0,25 mm <sup>2</sup>	---	2/3/4 x 0,25 mm <sup>2</sup>
Housing Material	Nickel-plated brass	Nickel-plated brass	Nickel-plated brass	Nickel-plated brass
Weight - Cable Output	---	145g	---	145g
Weight - M12 Connector Output	95g	---	95g	---



# BASIC M18

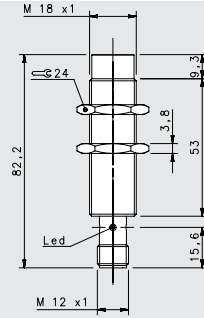
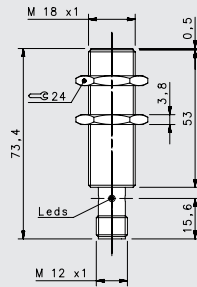

## STANDARD X2

				FLUSH	NON FLUSH
				M12 conn	M12 conn
NOMINAL SWITCHING DISTANCE				8 mm	14 mm
10-30 Vdc	PNP/NPN NO-NC	4 wires	order No.	---	---
10-30 Vdc	PNP NO	3 wires	order No.	IS-18-E1-S2 95B067050	IS-18-F1-S2 95B067040
10-30 Vdc	PNP NC	3 wires	order No.	---	---
10-30 Vdc	NPN NO	3 wires	order No.	---	---
10-30 Vdc	NPN NC	3 wires	order No.	---	---
10-30 Vdc	PNP NO-NC	3 wires	order No.	---	---
10-30 Vdc	NPN NO-NC	3 wires	order No.	---	---
10-30 Vdc	NO-NC	2 wires	order No.	---	---
20-250 Vac/Vdc	NO	2 wires	order No.	---	---
20-250 Vac/Vdc	NC	2 wires	order No.	---	---
20-250 Vac/Vdc	NO	2/3wires	order No.	---	---
Analog 0-20mA	-	3 wires	order No.	---	---
5+24 Vdc	NAMUR	2 wires	order No.	---	---

Nominal Voltage	10-30 Vdc (-15/10%)	10-30 Vdc (-15/10%)
Residual Ripple	< 10%	< 10%
Hysteresis	< 10%	< 10%
Max. Output Current	200 mA	200 mA
Min. Output Current	---	---
Residual Current	< 10 mA	< 10 mA
Voltage Drop	< 1,2 V (I=100mA)	< 1,2 V (I=100mA)
Operation Led	Yellow	Yellow
Switching Frequency	400 Hz	400 Hz
Start Up Delay	< 50 ms	< 50 ms
Repeability	< 3%	< 3%
Short Circuit Protection	Present (self-resetting)	Present (self-resetting)
Electric Protection	Against polarity reversal inductive loads	Against polarity reversal inductive loads
Temperature Limit	(-25 ... +70 °C)	(-25 ... +70 °C)
Protection Degree	IP67	IP67
Cable Length	---	---
Cable Section	---	---
Housing Material	Nickel-plated brass	Nickel-plated brass
Weight - Cable Output	---	145g
Weight - M12 Connector Output	95g	---



# BASIC M30

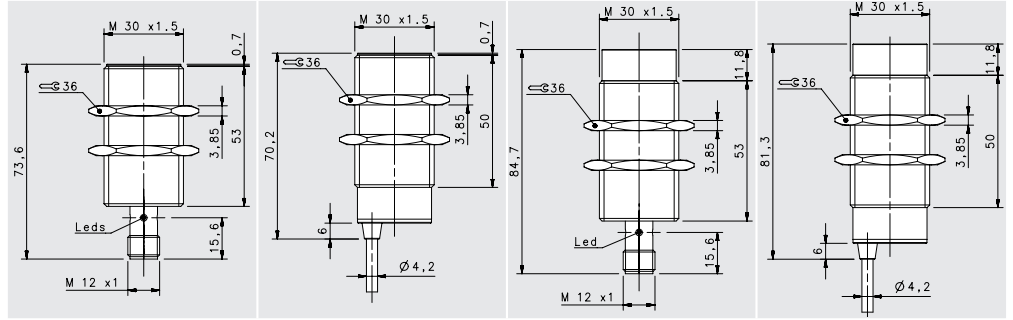
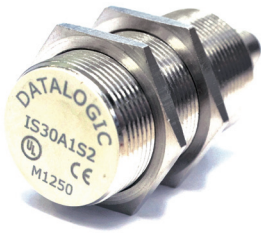

## STANDARD

### FLUSH

### NON FLUSH

M12 conn

cable

M12 conn

cable

### NOMINAL SWITCHING DISTANCE

				10 mm	10 mm	15 mm	15 mm
10-30 Vdc	PNP/NPN NO-NC	4 wires	order No.	IS-30-A0-S2 95B064490	IS-30-A0-03 95B064460	IS-30-C0-S2 95B064510	IS-30-C0-03 95B064470
10-30 Vdc	PNP NO	3 wires	order No.	IS-30-A1-S2 95B061431	IS-30-A1-03 95B061421	IS-30-C1-S2 95B061831	IS-30-C1-03 95B061821
10-30 Vdc	PNP NC	3 wires	order No.	IS-30-A2-S2 95B061451	IS-30-A2-03 95B061441	IS-30-C2-S2 95B061851	IS-30-C2-03 95B061841
10-30 Vdc	NPN NO	3 wires	order No.	IS-30-A3-S2 95B061391	IS-30-A3-03 95B061381	IS-30-C3-S2 95B061791	IS-30-C3-03 95B061781
10-30 Vdc	NPN NC	3 wires	order No.	IS-30-A4-S2 95B061411	IS-30-A4-03 95B061401	IS-30-C4-S2 95B061811	IS-30-C4-03 95B061801
10-30 Vdc	PNP NO-NC	3 wires	order No.	---	---	---	---
10-30 Vdc	NPN NO-NC	3 wires	order No.	---	---	---	---
10-30 Vdc	NO-NC	2 wires	order No.	IS-30-A9-S2 95B064570	IS-30-A9-03 95B064530	IS-30-C9-S2 95B064590	IS-30-C9-03 95B064550
20-250 Vac/Vdc	NO	2 wires	order No.	---	---	---	---
20-250 Vac/Vdc	NC	2 wires	order No.	---	---	---	---
20-250 Vac/Vdc	NO	2/3 wires	order No.	---	---	---	---
Analog 0-20mA	-	3 wires	order No.	---	---	---	---
5+24 Vdc	NAMUR	2 wires	order No.	---	---	---	---

Nominal Voltage	10-30 Vdc (-15%/10%)	10-30 Vdc (-15%/10%)	10-30 Vdc (-15%/10%)	10-30 Vdc (-15%/10%)
Residual Ripple	< 10%	< 10%	< 10%	< 10%
Hysteresis	< 10%	< 10%	< 10%	< 10%
Max. Output Current	200mA; 100 mA (2wires)	200mA; 100 mA (2wires)	200mA; 100 mA (2wires)	200mA; 100 mA (2wires)
Min. Output Current	> 1,6 mA (2wires)	> 1,6 mA (2wires)	> 1,6 mA (2wires)	> 1,6 mA (2wires)
Residual Current	< 1,6 mA	< 1,6 mA	< 1,6 mA	< 1,6 mA
Voltage Drop	< 1,8V; < 6,5 V (2wires)	< 1,8V; < 6,5 V (2wires)	< 1,8V; < 6,5 V (2wires)	< 1,8V; < 6,5 V (2wires)
Operation Led	Yellow	Yellow	Yellow	Yellow
Switching Frequency	300 Hz	300 Hz	300 Hz	300 Hz
Start Up Delay	< 50 ms	< 50 ms	< 50 ms	< 50 ms
Repeability	< 3%	< 3%	< 3%	< 3%
Short Circuit Protection	Present (self-resetting)	Present (self-resetting)	Present (self-resetting)	Present (self-resetting)
Electric Protection	Against polarity reversal inductive loads	Against polarity reversal inductive loads	Against polarity reversal inductive loads	Against polarity reversal inductive loads
Temperature Limit	(-25 ... +70 °C)	(-25 ... +70 °C)	(-25 ... +70 °C)	(-25 ... +70 °C)
Protection Degree	IP67	IP67	IP67	IP67
Cable Length	---	2 m	---	2 m
Cable Section	---	2/3/4 x 0,25 mm <sup>2</sup>	---	2/3/4 x 0,25 mm <sup>2</sup>
Housing Material	Nickel-plated brass	Nickel-plated brass	Nickel-plated brass	Nickel-plated brass
Weight - Cable Output	---	210 g	---	210 g
Weight - M12 Connector Output	170 g	---	170 g	---



# BASIC M30

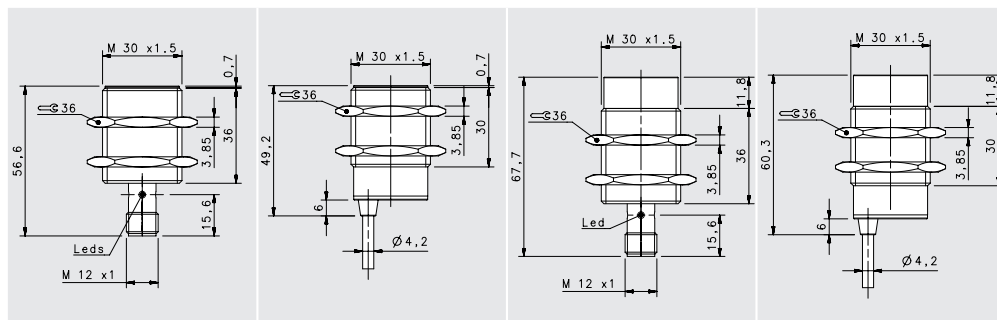
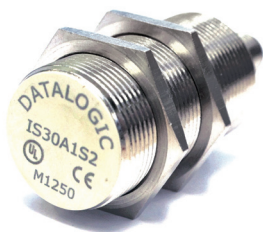

## SHORT X2

				FLUSH		NON FLUSH	
				M12 conn	cable	M12 conn	cable
NOMINAL SWITCHING DISTANCE				15mm	15mm	20 mm	20 mm
10-30 Vdc	PNP/NPN NO-NC	4 wires	order No.	IS-30-G0-S2 95B064500	IS-30-G0-03 95B063861	IS-30-H0-S2 95B064520	IS-30-H0-03 95B064480
10-30 Vdc	PNP NO	3 wires	order No.	IS-30-G1-S2 95B063691	IS-30-G1-03 95B063681	IS-30-H1-S2 95B063771	IS-30-H1-03 95B063761
10-30 Vdc	PNP NC	3 wires	order No.	IS-30-G2-S2 95B063711	IS-30-G2-03 95B063701	IS-30-H2-S2 95B063791	IS-30-H2-03 95B063781
10-30 Vdc	NPN NO	3 wires	order No.	IS-30-G3-S2 95B063651	IS-30-G3-03 95B063641	IS-30-H3-S2 95B063731	IS-30-H3-03 95B063721
10-30 Vdc	NPN NC	3 wires	order No.	IS-30-G4-S2 95B063671	IS-30-G4-03 95B063661	IS-30-H4-S2 95B063751	IS-30-H4-03 95B063741
10-30 Vdc	PNP NO-NC	3 wires	order No.	IS-30-G5-S2 95B063831	IS-30-G5-03 95B063821	IS-30-H5-S2 95B064450	IS-30-H5-03 95B064420
10-30 Vdc	NPN NO-NC	3 wires	order No.	IS-30-G6-S2 95B064430	IS-30-G6-03 95B064400	IS-30-H6-S2 95B064440	IS-30-H6-03 95B064410
10-30 Vdc	NO-NC	2 wires	order No.	IS-30-G9-S2 95B064580	IS-30-G9-03 95B064540	IS-30-H9-S2 95B064600	IS-30-H9-03 95B064560
20-250 Vac/Vdc	NO	2 wires	order No.	---	---	---	---
20-250 Vac/Vdc	NC	2 wires	order No.	---	---	---	---
20-250 Vac/Vdc	NO	2/3wires	order No.	---	---	---	---
Analog 0-20mA	-	3 wires	order No.	---	---	---	---
5+24 Vdc	NAMUR	2 wires	order No.	---	---	---	---

	10-30 Vdc (-15/10%)	10-30 Vdc (-15/10%)	10-30 Vdc (-15/10%)	10-30 Vdc (-15/10%)
Nominal Voltage	10-30 Vdc (-15/10%)	10-30 Vdc (-15/10%)	10-30 Vdc (-15/10%)	10-30 Vdc (-15/10%)
Residual Ripple	< 10%	< 10%	< 10%	< 10%
Hysteresis	< 10%	< 10%	< 10%	< 10%
Max. Output Current	200 mA	200 mA	200 mA	200 mA
Min. Output Current	---	---	---	---
Residual Current	< 10 mA	< 10 mA	< 10 mA	< 10 mA
Voltage Drop	< 1,2 V (I=100mA)	< 1,2 V (I=100mA)	< 1,2 V (I=100mA)	< 1,2 V (I=100mA)
Operation Led	Yellow	Yellow	Yellow	Yellow
Switching Frequency	200 Hz	200 Hz	200 Hz	200 Hz
Start Up Delay	< 75 ms	< 75 ms	< 75 ms	< 75 ms
Repeability	< 3%	< 3%	< 3%	< 3%
Short Circuit Protection	Present (self-resetting)	Present (self-resetting)	Present (self-resetting)	Present (self-resetting)
Electric Protection	Against polarity reversal inductive loads	Against polarity reversal inductive loads	Against polarity reversal inductive loads	Against polarity reversal inductive loads
Temperature Limit	(-25 ... +70 °C)	(-25 ... +70 °C)	(-25 ... +70 °C)	(-25 ... +70 °C)
Protection Degree	IP67	IP67	IP67	IP67
Cable Length	---	2 m	---	2 m
Cable Section	---	3 x 0,25 mm <sup>2</sup>	---	3 x 0,25 mm <sup>2</sup>
Housing Material	Nickel-plated brass	Nickel-plated brass	Nickel-plated brass	Nickel-plated brass
Weight - Cable Output	---	210 g	---	210 g
Weight - M12 Connector Output	170 g	---	170 g	---

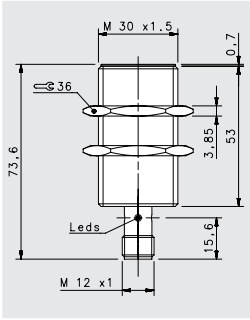

## STANDARD X2

### FLUSH

M12 conn

15 mm

---

---

IS-30-E1-52

95B067060

---

---

---

---

---

---

---

---

---

---

---

---

---

---

---

---

---

---

---

---

---

10-30 Vdc (-15/10%)

< 10%

< 10%

200 mA

---

< 10 mA

< 6,5 V (I=100mA)

Yellow

200 Hz

< 75 ms

< 3%

Present (self-resetting)

Against polarity reversal  
inductive loads

(-25 ... +70 °C)

IP67

---

---

Nickel-plated brass

---

170 g

# STAINLESS STEEL

Stainless Steel housing

Standard length

Short length

Normal and double range operating distance

Operating distance 0.8 ... 20 mm

M4, M5, M6,5, M8, M12, M18, M30

Cable, M8 or M12 connector

3 wires

PNP, NPN, NO, NC

IP67 protection

“M12/18/30 모델은 Diversey & ECOLAB 테스트(세제에 대한 부식)를 거친 제품입니다”



FLUSH 모델은 ATEX 인증 제품입니다



pag  
08

BASIC

pag  
32

STAINLESS  
STEEL

pag  
46

METAL  
FACE

pag  
50

WELD FIELD  
IMMUNE

pag  
54

INDUCTIVE AC

pag  
60

NAMUR

pag  
70

SQUARE

pag  
76

CABLES,  
CONNECTORS  
& ACCESSORIES



# STAINLESS STEEL

# STAINLESS STEEL M4

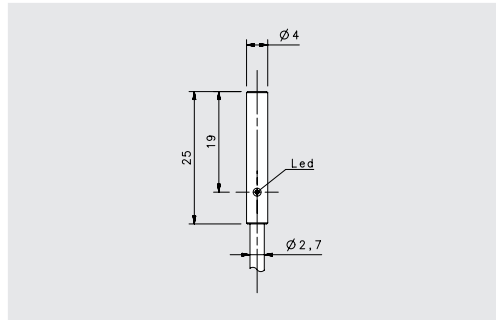

## STANDARD

FLUSH

cable

### NOMINAL SWITCHING DISTANCE

0,8 mm

10-30 Vdc	PNP/NPN NO-NC	4 wires	order No.	---
10-30 Vdc	PNP NO	3 wires	order No.	IS-04-A1-03 95B061011
10-30 Vdc	PNP NC	3 wires	order No.	---
10-30 Vdc	NPN NO	3 wires	order No.	IS-04-A3-03 95B061001
10-30 Vdc	NPN NC	3 wires	order No.	---
10-30 Vdc	PNP NO-NC	3 wires	order No.	---
10-30 Vdc	NPN NO-NC	3 wires	order No.	---
10-30 Vdc	NO-NC	2 wires	order No.	---
20-250 Vac/Vdc	NO	2 wires	order No.	---
20-250 Vac/Vdc	NC	2 wires	order No.	---
20-250 Vac/Vdc	NO	2/3wires	order No.	---
Analog 0-20mA	-	3 wires	order No.	---
5+24 Vdc	NAMUR	2 wires	order No.	---

Nominal Voltage	10-30 Vdc (-15/10%)
Residual Ripple	< 10%
Hysteresis	< 15%
Max. Output Current	100 mA
Min. Output Current	---
Residual Current	< 0,01 mA
Voltage Drop	< 1,5 V
Operation Led	Yellow
Switching Frequency	2000 Hz
Start Up Delay	---
Repeability	< 1%
Short Circuit Protection	Present (self-resetting)
Electric Protection	Against polarity reversal inductive loads
Temperature Limit	(-25 ... +70 °C)
Protection Degree	IP67
Cable Length	2 m (PUR)
Cable Section	3x 0,15 mm <sup>2</sup>
Housing Material	Stainless-Steel
Weight - Cable Output	50 g
Weight - M12 Connector Output	---

# STAINLESS STEEL M5

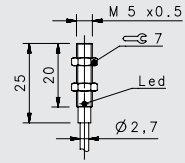
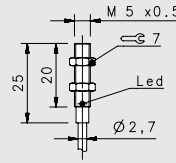
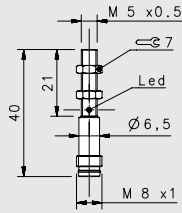

STAINLESS  
STEEL

## STANDARD

FLUSH

## STANDARD X2

FLUSH

### NOMINAL SWITCHING DISTANCE

				M8 conn	cable	cable
				0,8 mm	0,8 mm	1,5 mm
10-30 Vdc	PNP/NPN NO-NC	4 wires	order No.	---	---	---
10-30 Vdc	PNP NO	3 wires	order No.	IS-05-A1-S1 95B061051	IS-05-A1-03 95B061041	---
10-30 Vdc	PNP NC	3 wires	order No.	---	---	---
10-30 Vdc	NPN NO	3 wires	order No.	IS-05-A3-S1 95B061031	IS-05-A3-03 95B061021	IS-05-E3-03 95B065400
10-30 Vdc	NPN NC	3 wires	order No.	---	IS-05-A4-03 95B065420	---
10-30 Vdc	PNP NO-NC	3 wires	order No.	---	---	---
10-30 Vdc	NPN NO-NC	3 wires	order No.	---	---	---
10-30 Vdc	NO-NC	2 wires	order No.	---	---	---
20-250 Vac/Vdc	NO	2 wires	order No.	---	---	---
20-250 Vac/Vdc	NC	2 wires	order No.	---	---	---
20-250 Vac/Vdc	NO	2/3 wires	order No.	---	---	---
Analog 0-20mA	-	3 wires	order No.	---	---	---
5+24 Vdc	NAMUR	2 wires	order No.	---	---	---

	10-30 Vdc (-15/10%)	10-30 Vdc (-15/10%)	10-30 Vdc (-15/10%)
Nominal Voltage	10-30 Vdc (-15/10%)	10-30 Vdc (-15/10%)	10-30 Vdc (-15/10%)
Residual Ripple	< 10%	< 10%	< 10%
Hysteresis	< 15%	< 15%	< 15%
Max. Output Current	100 mA	100 mA	100 mA
Min. Output Current	---	---	---
Residual Current	< 0,01 mA	< 0,01 mA	< 0,01 mA
Voltage Drop	< 1,5V	< 1,5V	< 1,5V
Operation Led	Yellow	Yellow	Yellow
Switching Frequency	2000 Hz	2000 Hz	2000 Hz
Start Up Delay	---	---	---
Repeability	< 1%	< 1%	---
Short Circuit Protection	Present (self-resetting)	Present (self-resetting)	Present (self-resetting)
Electric Protection	Against polarity reversal inductive loads	Against polarity reversal inductive loads	Against polarity reversal inductive loads
Temperature Limit	(-25 ... +70 °C)	(-25 ... +70 °C)	(-25 ... +70 °C)
Protection Degree	IP67	IP67	IP67
Cable Length	---	2 m (PUR)	2 m (PUR)
Cable Section	---	3x 0,15 mm <sup>2</sup>	3x 0,15 mm <sup>2</sup>
Housing Material	Stainless-Steel	Stainless-Steel	Stainless-Steel
Weight - Cable Output	---	25g	25g
Weight - M12 Connector Output	14g	---	---

# STAINLESS STEEL M6,5

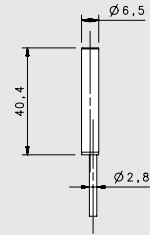
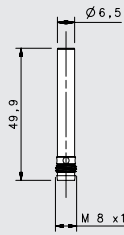

## SHORT STAINLESS STEEL

FLUSH

M8 conn

cable

### NOMINAL SWITCHING DISTANCE

				1,5 mm	1,5 mm
10-30 Vdc	PNP/NPN NO-NC	4 wires	order No.	---	---
10-30 Vdc	PNP NO	3 wires	order No.	IS-65-M1-S1 95B066080	IS-65-M1-03 95B064760
10-30 Vdc	PNP NC	3 wires	order No.	IS-65-M2-S1 95B066120	IS-65-M2-03 95B064800
10-30 Vdc	NPN NO	3 wires	order No.	IS-65-M3-S1 95B066000	IS-65-M3-03 95B064680
10-30 Vdc	NPN NC	3 wires	order No.	IS-65-M4-S1 95B066040	IS-65-M4-03 95B064720
10-30 Vdc	PNP NO-NC	3 wires	order No.	---	---
10-30 Vdc	NPN NO-NC	3 wires	order No.	---	---
10-30 Vdc	NO-NC	2 wires	order No.	---	---
20-250 Vac/Vdc	NO	2 wires	order No.	---	---
20-250 Vac/Vdc	NC	2 wires	order No.	---	---
20-250 Vac/Vdc	NO	2/3wires	order No.	---	---
Analog 0-20mA	-	3 wires	order No.	---	---
5+24 Vdc	NAMUR	2 wires	order No.	---	---

Nominal Voltage	10-30 Vdc (-15/10%)	10-30 Vdc (-15/10%)
Residual Ripple	< 10%	< 10%
Hysteresis	< 10%	< 10%
Max. Output Current	200 mA	200 mA
Min. Output Current	---	---
Residual Current	< 10 mA	< 10 mA
Voltage Drop	< 1,2 V (I=100mA)	< 1,2 V (I=100mA)
Operation Led	Yellow	Yellow
Switching Frequency	1000 Hz	1000 Hz
Start Up Delay	< 50 ms	< 50 ms
Repeability	< 3%	< 3%
Short Circuit Protection	Present (self-resetting)	Present (self-resetting)
Electric Protection	Against polarity reversal inductive loads	Against polarity reversal inductive loads
Temperature Limit	(-25 ... +70 °C)	(-25 ... +70 °C)
Protection Degree	IP67	IP67
Cable Length	---	---
Cable Section	---	3x 0,14 mm <sup>2</sup>
Housing Material	Stainless-Steel	Stainless-Steel
Weight - Cable Output	---	80 g
Weight - M12 Connector Output	40 g	---



# STAINLESS STEEL M8

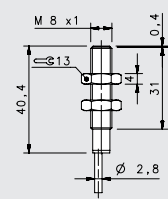
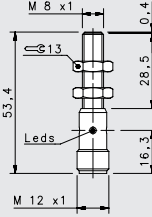
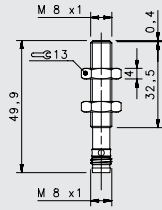

## SHORT STAINLESS STEEL

FLUSH

### NOMINAL SWITCHING DISTANCE

				M8 conn	M12 conn	cable
				1,5 mm	1,5 mm	1,5 mm
10-30 Vdc	PNP/NPN NO-NC	4 wires	order No.	---	---	---
10-30 Vdc	PNP NO	3 wires	order No.	IS-08-M1-S1 95B066870	IS-08-M1-S2 95B066600	IS-08-M1-03 95B066380
10-30 Vdc	PNP NC	3 wires	order No.	IS-08-M2-S1 95B066900	IS-08-M2-S2 95B066630	IS-08-M2-03 95B066600
10-30 Vdc	NPN NO	3 wires	order No.	IS-08-M3-S1 95B066820	IS-08-M3-S2 95B066540	IS-08-M3-03 95B066340
10-30 Vdc	NPN NC	3 wires	order No.	IS-08-M4-S1 95B066840	IS-08-M4-S2 95B066570	IS-08-M4-03 95B066360
10-30 Vdc	PNP NO-NC	3 wires	order No.	---	---	---
10-30 Vdc	NPN NO-NC	3 wires	order No.	---	---	---
10-30 Vdc	NO-NC	2 wires	order No.	---	---	---
20-250 Vac/Vdc	NO	2 wires	order No.	---	---	---
20-250 Vac/Vdc	NC	2 wires	order No.	---	---	---
20-250 Vac/Vdc	NO	2/3 wires	order No.	---	---	---
Analog 0-20mA	-	3 wires	order No.	---	---	---
5+24 Vdc	NAMUR	2 wires	order No.	---	---	---

	10-30 Vdc (-15/10%)	10-30 Vdc (-15/10%)	10-30 Vdc (-15/10%)
Nominal Voltage	10-30 Vdc (-15/10%)	10-30 Vdc (-15/10%)	10-30 Vdc (-15/10%)
Residual Ripple	< 10%	< 10%	< 10%
Hysteresis	< 10%	< 10%	< 10%
Max. Output Current	200 mA	200 mA	200 mA
Min. Output Current	---	---	---
Residual Current	< 10 mA	< 10 mA	< 10 mA
Voltage Drop	< 1,2 V (I=100mA)	< 1,2 V (I=100mA)	< 1,2 V (I=100mA)
Operation Led	Yellow	Yellow	Yellow
Switching Frequency	1000 Hz	1000 Hz	1000 Hz
Start Up Delay	< 50 ms	< 50 ms	< 50 ms
Repeability	< 3%	< 3%	< 3%
Short Circuit Protection	Present (self-resetting)	Present (self-resetting)	Present (self-resetting)
Electric Protection	Against polarity reversal inductive loads	Against polarity reversal inductive loads	Against polarity reversal inductive loads
Temperature Limit	(-25 ... +70 °C)	(-25 ... +70 °C)	(-25 ... +70 °C)
Protection Degree	IP67	IP67	IP67
Cable Length	---	---	---
Cable Section	---	---	3x 0,14 mm <sup>2</sup>
Housing Material	Stainless-Steel	Stainless-Steel	Stainless-Steel
Weight - Cable Output	---	---	80 g
Weight - M12 Connector Output	35g	55g	---



# STAINLESS STEEL M12

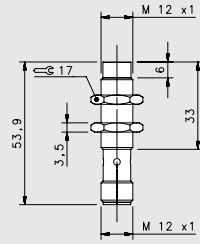
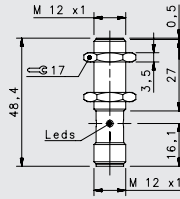

## SHORT STAINLESS STEEL

				FLUSH	NON FLUSH
				M12 conn	M12 conn
NOMINAL SWITCHING DISTANCE				2 mm	4 mm
10-30 Vdc	PNP/NPN NO-NC	4 wires	order No.	---	---
10-30 Vdc	PNP NO	3 wires	order No.	IS-12-M1-S2 95B060240	IS-12-N1-S2 95B060280
10-30 Vdc	PNP NC	3 wires	order No.	IS-12-M2-S2 95B060250	IS-12-N2-S2 95B060290
10-30 Vdc	NPN NO	3 wires	order No.	IS-12-M3-S2 95B060260	IS-12-N3-S2 95B060300
10-30 Vdc	NPN NC	3 wires	order No.	IS-12-M4-S2 95B060270	IS-12-N4-S2 95B060310
10-30 Vdc	PNP NO-NC	3 wires	order No.	---	---
10-30 Vdc	NPN NO-NC	3 wires	order No.	---	---
10-30 Vdc	NO-NC	2 wires	order No.	---	---
20-250 Vac/Vdc	NO	2 wires	order No.	---	---
20-250 Vac/Vdc	NC	2 wires	order No.	---	---
20-250 Vac/Vdc	NO	2/3wires	order No.	---	---
Analog 0-20mA	-	3 wires	order No.	---	---
5+24 Vdc	NAMUR	2 wires	order No.	---	---

Nominal Voltage	10-30 Vdc (-15/10%)	10-30 Vdc (-15/10%)
Residual Ripple	< 10%	< 10%
Hysteresis	< 10%	< 10%
Max. Output Current	200 mA	200 mA
Min. Output Current	---	---
Residual Current	< 10 mA	< 10 mA
Voltage Drop	< 1,8 V (I=100mA)	< 1,8 V (I=100mA)
Operation Led	Yellow	Yellow
Switching Frequency	1000 Hz	1000 Hz
Start Up Delay	< 50 ms	< 50 ms
Repeability	< 3%	< 3%
Short Circuit Protection	Present (self-resetting)	Present (self-resetting)
Electric Protection	Against polarity reversal inductive loads	Against polarity reversal inductive loads
Temperature Limit	(-25 ... +60 °C)	(-25 ... +60 °C)
Protection Degree	IP67	IP67
Cable Length	---	---
Cable Section	---	---
Housing Material	Stainless-Steel	Stainless-Steel
Weight - Cable Output	---	---
Weight - M12 Connector Output	60 g	60 g

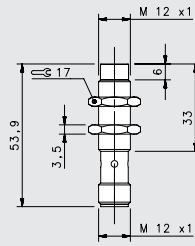
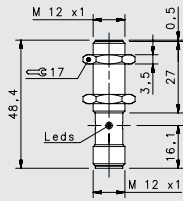

## SHORT STAINLESS STEEL X2

FLUSH	NON FLUSH
M12 conn	M12 conn
<b>4 mm</b>	<b>8 mm</b>
---	---
IS-12-01-S2	IS-12-P1-S2
95B060000	95B060040
IS-12-02-S2	IS-12-P2-S2
95B060010	95B060050
IS-12-03-S2	IS-12-P3-S2
95B060020	95B060060
IS-12-04-S2	IS-12-P4-S2
95B060030	95B060070
---	---
---	---
---	---
---	---
---	---
---	---
---	---
---	---
---	---
---	---
---	---
---	---
---	---
---	---
---	---
---	---
10-30 Vdc (-15/10%)	10-30 Vdc (-15/10%)
< 10%	< 10%
< 10%	< 10%
200 mA	200 mA
---	---
< 10 mA	< 10 mA
< 1,2 V (I=100mA)	< 1,2 V (I=100mA)
Yellow	Yellow
500 Hz	500 Hz
< 75 ms	< 75 ms
< 3%	< 3%
Present (self-resetting)	Present (self-resetting)
Against polarity reversal inductive loads	Against polarity reversal inductive loads
(-25 ... +60 °C)	(-25 ... +60 °C)
IP67	IP67
---	---
---	---
Stainless-Steel	Stainless-Steel
---	---
60 g	60 g

# STAINLESS STEEL M18

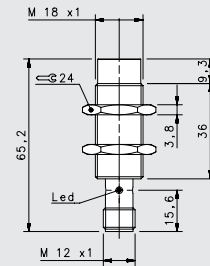
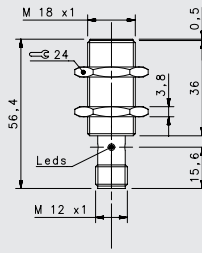

## SHORT STAINLESS STEEL

FLUSH

NON FLUSH

M12 conn

M12 conn

5 mm

8 mm

### NOMINAL SWITCHING DISTANCE

10-30 Vdc	PNP/NPN NO-NC	4 wires	order No.	---	---
10-30 Vdc	PNP NO	3 wires	order No.	IS-18-M1-S2 95B060320	IS-18-N1-S2 95B060360
10-30 Vdc	PNP NC	3 wires	order No.	IS-18-M2-S2 95B060330	IS-18-N2-S2 95B060370
10-30 Vdc	NPN NO	3 wires	order No.	IS-18-M3-S2 95B060340	IS-18-N3-S2 95B060380
10-30 Vdc	NPN NC	3 wires	order No.	IS-18-M4-S2 95B060350	IS-18-N4-S2 95B060390
10-30 Vdc	PNP NO-NC	3 wires	order No.	---	---
10-30 Vdc	NPN NO-NC	3 wires	order No.	---	---
10-30 Vdc	NO-NC	2 wires	order No.	---	---
20-250 Vac/Vdc	NO	2 wires	order No.	---	---
20-250 Vac/Vdc	NC	2 wires	order No.	---	---
20-250 Vac/Vdc	NO	2/3wires	order No.	---	---
Analog 0-20mA	-	3 wires	order No.	---	---
5+24 Vdc	NAMUR	2 wires	order No.	---	---

Nominal Voltage	10-30 Vdc (-15/10%)	10-30 Vdc (-15/10%)
Residual Ripple	< 10%	< 10%
Hysteresis	< 10%	< 10%
Max. Output Current	200 mA	200 mA
Min. Output Current	---	---
Residual Current	< 10 mA	< 10 mA
Voltage Drop	< 1,8 V (I=100mA)	< 1,8 V (I=100mA)
Operation Led	Yellow	Yellow
Switching Frequency	1000 Hz	1000 Hz
Start Up Delay	< 50 ms	< 50 ms
Repeability	< 3%	< 3%
Short Circuit Protection	Present (self-resetting)	Present (self-resetting)
Electric Protection	Against polarity reversal inductive loads	Against polarity reversal inductive loads
Temperature Limit	(-25 ... +60 °C)	(-25 ... +60 °C)
Protection Degree	IP67	IP67
Cable Length	---	---
Cable Section	---	---
Housing Material	Stainless-Steel	Stainless-Steel
Weight - Cable Output	---	---
Weight - M12 Connector Output	95g	95g

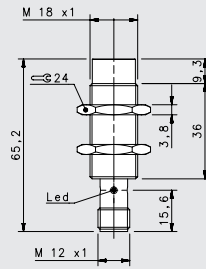
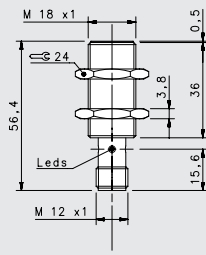

## SHORT STAINLESS STEEL X2

FLUSH	NON FLUSH
M12 conn	M12 conn
<b>8 mm</b>	<b>14 mm</b>
---	---
---	---
IS-18-01-S2	IS-18-P1-S2
95B060080	95B060120
IS-18-02-S2	IS-18-P2-S2
95B060090	95B060130
IS-18-03-S2	IS-18-P3-S2
95B060100	95B060140
IS-18-04-S2	IS-18-P4-S2
95B060110	95B060150
---	---
---	---
---	---
---	---
---	---
---	---
---	---
---	---
---	---
---	---
---	---
---	---
---	---
---	---
---	---
---	---
---	---
---	---
10-30 Vdc (-15/10%)	10-30 Vdc (-15/10%)
< 10%	< 10%
< 10%	< 10%
200 mA	200 mA
---	---
< 10 mA	< 10 mA
< 1,2 V (I=100mA)	< 1,2 V (I=100mA)
Yellow	Yellow
400 Hz	400 Hz
< 75 ms	< 75 ms
< 3%	< 3%
Present (self-resetting)	Present (self-resetting)
Against polarity reversal inductive loads	Against polarity reversal inductive loads
(-25 ... +70 °C)	(-25 ... +70 °C)
IP67	IP67
---	---
---	---
Stainless-Steel	Stainless-Steel
---	---
95g	95g

# STAINLESS STEEL M30

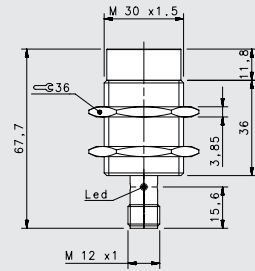
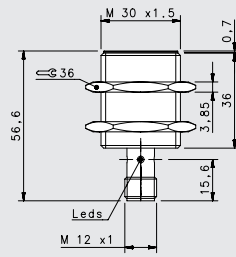

## SHORT STAINLESS STEEL

				FLUSH	NON FLUSH
				M12 conn	M12
NOMINAL SWITCHING DISTANCE				10 mm	15 mm
10-30 Vdc	PNP/NPN NO-NC	4 wires	order No.	---	---
10-30 Vdc	PNP NO	3 wires	order No.	IS-30-M1-S2 95B060400	IS-30-N1-S2 95B060440
10-30 Vdc	PNP NC	3 wires	order No.	IS-30-M2-S2 95B060410	IS-30-N2-S2 95B060450
10-30 Vdc	NPN NO	3 wires	order No.	IS-30-M3-S2 95B060420	IS-30-N3-S2 95B060460
10-30 Vdc	NPN NC	3 wires	order No.	IS-30-M4-S2 95B060430	IS-30-N4-S2 95B060470
10-30 Vdc	PNP NO-NC	3 wires	order No.	---	---
10-30 Vdc	NPN NO-NC	3 wires	order No.	---	---
10-30 Vdc	NO-NC	2 wires	order No.	---	---
20-250 Vac/Vdc	NO	2 wires	order No.	---	---
20-250 Vac/Vdc	NC	2 wires	order No.	---	---
20-250 Vac/Vdc	NO	2/3wires	order No.	---	---
Analog 0-20mA	-	3 wires	order No.	---	---
5+24 Vdc	NAMUR	2 wires	order No.	---	---

Nominal Voltage	10-30 Vdc (-15/10%)	10-30 Vdc (-15/10%)
Residual Ripple	< 10%	< 10%
Hysteresis	< 10%	< 10%
Max. Output Current	200 mA	200 mA
Min. Output Current	---	---
Residual Current	< 10 mA	< 10 mA
Voltage Drop	< 1,8 V (I=100mA)	< 1,8 V (I=100mA)
Operation Led	Yellow	Yellow
Switching Frequency	300 Hz	300 Hz
Start Up Delay	< 50 ms	< 50 ms
Repeability	< 3%	< 3%
Short Circuit Protection	Present (self-resetting)	Present (self-resetting)
Electric Protection	Against polarity reversal inductive loads	Against polarity reversal inductive loads
Temperature Limit	(-25 ... +60 °C)	(-25 ... +60 °C)
Protection Degree	IP67	IP67
Cable Length	---	---
Cable Section	---	---
Housing Material	Stainless-Steel	Stainless-Steel
Weight - Cable Output	---	---
Weight - M12 Connector Output	170 g	170 g

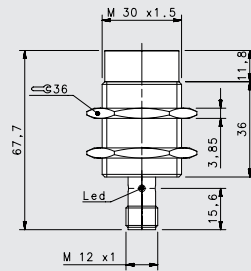
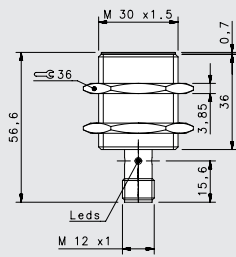

## SHORT STAINLESS STEEL X2

FLUSH	NON FLUSH
M12 conn	M12 conn
<b>15 mm</b>	<b>20 mm</b>
---	---
---	---
IS-30-01-S2	IS-30-P1-S2
95B060160	95B060200
IS-30-02-S2	IS-30-P2-S2
95B060180	95B060210
IS-30-03-S2	IS-30-P3-S2
95B060180	95B060220
IS-30-04-S2	IS-30-P4-S2
95B060190	95B060230
---	---
---	---
---	---
---	---
---	---
---	---
---	---
---	---
---	---
---	---
---	---
---	---
---	---
---	---
---	---
---	---
---	---
10-30 Vdc (-15/10%)	10-30 Vdc (-15/10%)
< 10%	< 10%
< 10%	< 10%
200 mA	200 mA
---	---
< 10 mA	< 10 mA
< 1,2 V (I=100mA)	< 1,2 V (I=100mA)
Yellow	Yellow
200 Hz	200 Hz
< 75 ms	< 75 ms
< 3%	< 3%
Present (self-resetting)	Present (self-resetting)
Against polarity reversal inductive loads	Against polarity reversal inductive loads
(-25 ... +70 °C)	(-25 ... +70 °C)
IP67	IP67
---	---
---	---
Stainless-Steel	Stainless-Steel
---	---
170 g	170 g

# METAL FACE

Stainless Steel housing  
Stainless Steel active face  
Standard length  
2 ... 8 mm  
M12, M18  
M12 connector  
3 wires  
PNP, NO  
IP67 protection

“M12/18/30 모델은 Diversey & ECOLAB 테스트(세제에 대한 부식)를 거친 제품입니다”



M12/18/30 FLUSH 모델은 ATEX 인증을 받은 제품입니다



pag  
08

BASIC

pag  
32

STAINLESS  
STEEL

pag  
46

METAL  
FACE

pag  
50

WELD FIELD  
IMMUNE

pag  
54

INDUCTIVE AC

pag  
60

NAMUR

pag  
70

SQUARE

pag  
76

CABLES,  
CONNECTORS  
& ACCESSORIES



# METAL FACE

# METAL FACE M12

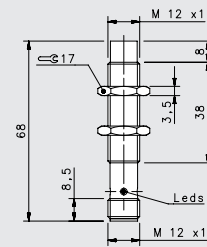
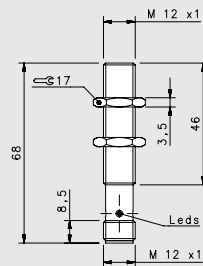

## METAL FACE

### FLUSH

### NON FLUSH

M12 conn

M12 conn

### NOMINAL SWITCHING DISTANCE

				2 mm	4 mm
10-30 Vdc	PNP/NPN NO-NC	4 wires	order No.	---	---
10-30 Vdc	PNP NO	3 wires	order No.	IS-12-L1-52 95B065340	IS-12-L1-52 95B063871
10-30 Vdc	PNP NC	3 wires	order No.	---	---
10-30 Vdc	NPN NO	3 wires	order No.	---	---
10-30 Vdc	NPN NC	3 wires	order No.	---	---
10-30 Vdc	PNP NO-NC	3 wires	order No.	---	---
10-30 Vdc	NPN NO-NC	3 wires	order No.	---	---
10-30 Vdc	NO-NC	2 wires	order No.	---	---
20-250 Vac/Vdc	NO	2 wires	order No.	---	---
20-250 Vac/Vdc	NC	2 wires	order No.	---	---
20-250 Vac/Vdc	NO	2/3wires	order No.	---	---
Analog 0-20mA	-	3 wires	order No.	---	---
5+24 Vdc	NAMUR	2 wires	order No.	---	---

Nominal Voltage	10-30 Vdc	10-30 Vdc
Residual Ripple	< 10%	< 10%
Hysteresis	< 15%	< 15%
Max. Output Current	200 mA	200 mA
Min. Output Current	---	---
Residual Current	< 0,01 mA	< 0,01 mA
Voltage Drop	< 1,5 V (I=100mA)	< 1,5 V (I=100mA)
Operation Led	Present	Present
Switching Frequency	2000 Hz	1000 Hz
Start Up Delay	---	---
Repeability	< 1%	< 1%
Short Circuit Protection	Present (self-resetting)	Present (self-resetting)
Electric Protection	Against polarity reversal inductive loads	Against polarity reversal inductive loads
Temperature Limit	(-25 ... +70 °C)	(-25 ... +70 °C)
Protection Degree	IP67	IP67
Cable Length	---	---
Cable Section	---	---
Housing Material	Stainless-Steel	Stainless-Steel
Weight - Cable Output	---	---
Weight - M12 Connector Output	30 g	30 g

# METAL FACE M18

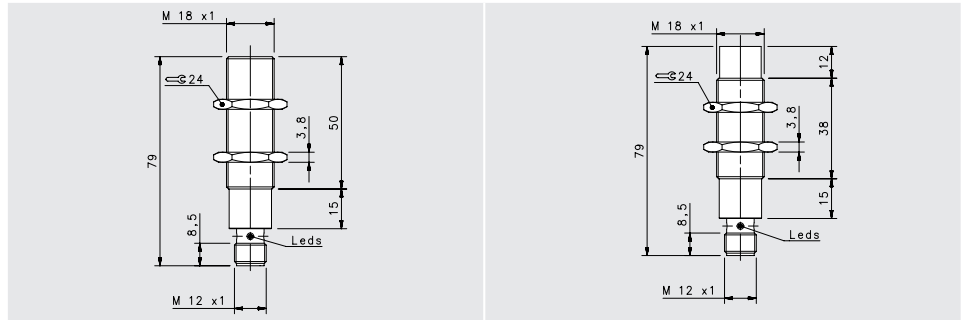

## METAL FACE

METAL FACE

				FLUSH	NON FLUSH
				M12 conn	M12 conn
NOMINAL SWITCHING DISTANCE				5 mm	8 mm

				M12 conn	M12 conn
NOMINAL SWITCHING DISTANCE				5 mm	8 mm
10-30 Vdc	PNP/NPN NO-NC	4 wires	order No.	---	---
10-30 Vdc	PNP NO	3 wires	order No.	IS-18-I1-S2 95B065350	IS-18-L1-S2 95B063881
10-30 Vdc	PNP NC	3 wires	order No.	---	---
10-30 Vdc	NPN NO	3 wires	order No.	---	---
10-30 Vdc	NPN NC	3 wires	order No.	---	---
10-30 Vdc	PNP NO-NC	3 wires	order No.	---	---
10-30 Vdc	NPN NO-NC	3 wires	order No.	---	---
10-30 Vdc	NO-NC	2 wires	order No.	---	---
20-250 Vac/Vdc	NO	2 wires	order No.	---	---
20-250 Vac/Vdc	NC	2 wires	order No.	---	---
20-250 Vac/Vdc	NO	2/3wires	order No.	---	---
Analog 0-20mA	-	3 wires	order No.	---	---
5+24 Vdc	NAMUR	2 wires	order No.	---	---

Nominal Voltage	10-30 Vdc	10-30 Vdc
Residual Ripple	< 10%	< 10%
Hysteresis	< 15%	< 15%
Max. Output Current	200 mA	200 mA
Min. Output Current	> 1,6 mA	> 1,6 mA
Residual Current	< 0,01 mA	< 0,01 mA
Voltage Drop	< 1,5 V	< 1,5 V
Operation Led	Present	Present
Switching Frequency	1000 Hz	500 Hz
Start Up Delay	---	---
Repeability	< 1%	< 1%
Short Circuit Protection	Present (self-resetting)	Present (self-resetting)
Electric Protection	Against polarity reversal inductive loads	Against polarity reversal inductive loads
Temperature Limit	(-25 ... +70 °C)	(-25 ... +70 °C)
Protection Degree	IP67	IP67
Cable Length	---	---
Cable Section	---	---
Housing Material	Stainless-Steel	Stainless-Steel
Weight - Cable Output	---	---
Weight - M12 Connector Output	95g	95g

# WELD FIELD IMMUNE

Stainless Steel housing

PTFE active face

Standard length

Operating distance 2 ... 8 mm

M12, M18

M12 connector

3 wires

PNP, NO

IP67 protection

~M12/18/30 모델은 Diversey & ECOLAB 테스트(세제에 대한 부식)를 거친 제품입니다~



M12/18/30 FLUSH 모델은 ATEX 인증을 받은 제품입니다



pag  
08

BASIC

pag  
32

STAINLESS  
STEEL

pag  
46

METAL  
FACE

pag  
50

WELD FIELD  
IMMUNE

pag  
54

INDUCTIVE AC

pag  
60

NAMUR

pag  
70

SQUARE

pag  
76

CABLES,  
CONNECTORS  
& ACCESSORIES



# WELD FIELD IMMUNE

# WELD FIELD IMMUNE M12

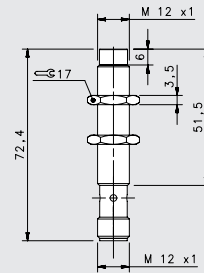
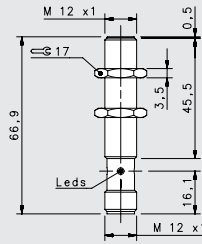

## FIELD IMMUNE STAINLESS STEEL

FLUSH

NON FLUSH

M12 conn

M12 conn

### NOMINAL SWITCHING DISTANCE

				2 mm	4 mm
10-30 Vdc	PNP/NPN NO-NC	4 wires	order No.	---	---
10-30 Vdc	PNP NO	3 wires	order No.	IS-F12-S1-S2 95B065360	IS-F12-T1-S2 95B065370
10-30 Vdc	PNP NC	3 wires	order No.	---	---
10-30 Vdc	NPN NO	3 wires	order No.	---	---
10-30 Vdc	NPN NC	3 wires	order No.	---	---
10-30 Vdc	PNP NO-NC	3 wires	order No.	---	---
10-30 Vdc	NPN NO-NC	3 wires	order No.	---	---
10-30 Vdc	NO-NC	2 wires	order No.	---	---
20-250 Vac/Vdc	NO	2 wires	order No.	---	---
20-250 Vac/Vdc	NC	2 wires	order No.	---	---
20-250 Vac/Vdc	NO	2/3wires	order No.	---	---
Analog 0-20mA	-	3 wires	order No.	---	---
5+24 Vdc	NAMUR	2 wires	order No.	---	---

Nominal Voltage	10-30 Vdc	10-30 Vdc
Residual Ripple	< 10%	< 10%
Hysteresis	< 15%	< 15%
Max. Output Current	200 mA	200 mA
Min. Output Current	< 10mA	< 10mA
Residual Current	< 0,1 mA	< 0,1 mA
Voltage Drop	< 1,5V	< 1,5V
Operation Led	Present	Present
Switching Frequency	2000 Hz	1000 Hz
Start Up Delay	< 0,1 ms	< 0,1 ms
Repeability	< 1%	< 1%
Short Circuit Protection	Present (self-resetting)	Present (self-resetting)
Electric Protection	Against polarity reversal inductive loads	Against polarity reversal inductive loads
Temperature Limit	(-25 ... +70 °C)	(-25 ... +70 °C)
Protection Degree	IP67	IP67
Cable Length	---	---
Cable Section	---	---
Housing Material	Stainless-Steel	Stainless-Steel
Weight - Cable Output	---	---
Weight - M12 Connector Output	25g	23g

# WELD FIELD IMMUNE M18

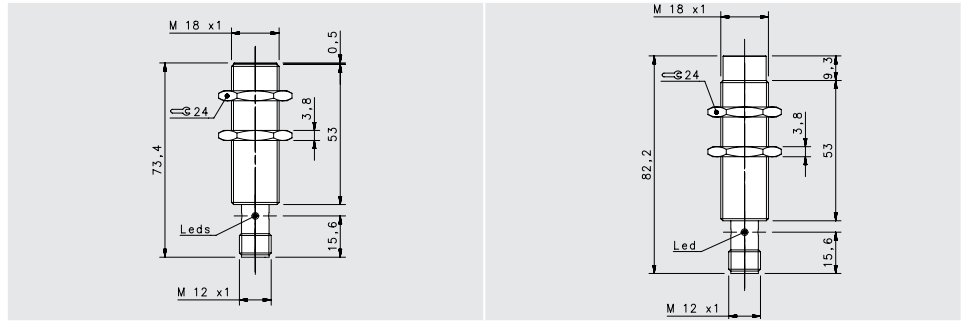

## FIELD IMMUNE STAINLESS STEEL

				FLUSH	NON FLUSH
				M12 conn	M12 conn
NOMINAL SWITCHING DISTANCE				5 mm	8 mm
10-30 Vdc	PNP/NPN NO-NC	4 wires	order No.	---	---
10-30 Vdc	PNP NO	3 wires	order No.	IS-F18-S1-52 95B065380	IS-F18-T1-52 95B065390
10-30 Vdc	PNP NC	3 wires	order No.	---	---
10-30 Vdc	NPN NO	3 wires	order No.	---	---
10-30 Vdc	NPN NC	3 wires	order No.	---	---
10-30 Vdc	PNP NO-NC	3 wires	order No.	---	---
10-30 Vdc	NPN NO-NC	3 wires	order No.	---	---
10-30 Vdc	NO-NC	2 wires	order No.	---	---
20-250 Vac/Vdc	NO	2 wires	order No.	---	---
20-250 Vac/Vdc	NC	2 wires	order No.	---	---
20-250 Vac/Vdc	NO	2/3wires	order No.	---	---
Analog 0-20mA	-	3 wires	order No.	---	---
5+24 Vdc	NAMUR	2 wires	order No.	---	---

Nominal Voltage	10-30 Vdc	10-30 Vdc
Residual Ripple	< 10%	< 10%
Hysteresis	< 15%	< 15%
Max. Output Current	200 mA	200 mA
Min. Output Current	< 10mA	< 10mA
Residual Current	< 0,1 mA	< 0,1 mA
Voltage Drop	< 1,5V	< 1,5V
Operation Led	Present	Present
Switching Frequency	1000 Hz	500 Hz
Start Up Delay	< 0,2 ms	< 0,5 ms
Repeability	< 1%	< 1%
Short Circuit Protection	Present (self-resetting)	Present (self-resetting)
Electric Protection	Against polarity reversal inductive loads	Against polarity reversal inductive loads
Temperature Limit	(-25 ... +70 °C)	(-25 ... +70 °C)
Protection Degree	IP67	IP67
Cable Length	---	---
Cable Section	---	---
Housing Material	Stainless-Steel	Stainless-Steel
Weight - Cable Output	---	---
Weight - M12 Connector Output	94g	91g

# INDUCTIVE AC

Nickel-plated Brass housing  
Standard length  
Operating distance 2 ... 10 mm  
M12, M18, M30  
cable or M12 connector  
20+250 Vac (50,60 Hz)  
2 or 3 wires  
NO  
IP67 protection

~M12/18/30 모델은 Diversey & ECOLAB 테스트(세제에 대한 부식)를 거친 제품입니다~



M12/18/30 FLUSH 모델은 ATEX 인증을 받은 제품입니다



pag  
08

BASIC

pag  
32

STAINLESS  
STEEL

pag  
46

METAL  
FACE

pag  
50

WELD FIELD  
IMMUNE

pag  
54

INDUCTIVE AC

pag  
60

NAMUR

pag  
70

SQUARE

pag  
76

CABLES,  
CONNECTORS  
& ACCESSORIES



# INDUCTIVE AC

# INDUCTIVE AC M12

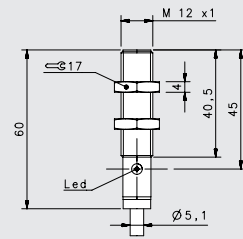
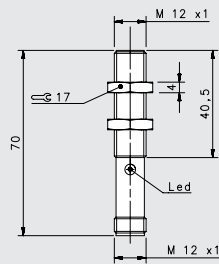

## STANDARD VAC

FLUSH

M12 conn

cable

### NOMINAL SWITCHING DISTANCE

				2 mm	2 mm
10-30 Vdc	PNP/NPN NO-NC	4 wires	order No.	---	---
10-30 Vdc	PNP NO	3 wires	order No.	---	---
10-30 Vdc	PNP NC	3 wires	order No.	---	---
10-30 Vdc	NPN NO	3 wires	order No.	---	---
10-30 Vdc	NPN NC	3 wires	order No.	---	---
10-30 Vdc	PNP NO-NC	3 wires	order No.	---	---
10-30 Vdc	NPN NO-NC	3 wires	order No.	---	---
10-30 Vdc	NO-NC	2 wires	order No.	---	---
20-250 Vac/Vdc	NO	2 wires	order No.	---	---
20-250 Vac/Vdc	NC	2 wires	order No.	---	---
20-250 Vac/Vdc	NO	2/3wires	order No.	IS-12-A15-S2 95B060690	IS-12-A15-03 95B060680
Analog 0-20mA	-	3 wires	order No.	---	---
5+24 Vdc	NAMUR	2 wires	order No.	---	---

Nominal Voltage	20+250 Vac (50,60 Hz)	20+250 Vac (50,60 Hz)
Residual Ripple	< 10%	< 10%
Hysteresis	< 10%	< 10%
Max. Output Current	500 mA, inrush:1,5A	500 mA, inrush:1,5A
Min. Output Current	20 mA	20 mA
Residual Current	< 0,7 mA	< 0,7 mA
Voltage Drop	< 4 V (I=100mA)	< 4 V (I=100mA)
Operation Led	Yellow	Yellow
Switching Frequency	25 Hz	25 Hz
Start Up Delay	< 300 ms	< 300 ms
Repeability	5%	5%
Short Circuit Protection	Present (self-resetting)	Present (self-resetting)
Electric Protection	Against polarity reversal inductive loads	Against polarity reversal inductive loads
Temperature Limit	(-25 ... +70 °C)	(-25 ... +70 °C)
Protection Degree	IP67	IP67
Cable Length	---	2 m
Cable Section	---	2 x 0,25 mm <sup>2</sup>
Housing Material	Nickel-plated brass	Nickel-plated brass
Weight - Cable Output	---	145g
Weight - M12 Connector Output	95g	---

# INDUCTIVE AC M18

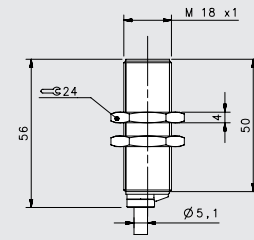
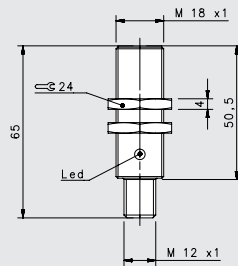

## STANDARD VAC

FLUSH

M12 conn

cable

### NOMINAL SWITCHING DISTANCE

				5 mm	5 mm
10-30 Vdc	PNP/NPN NO-NC	4 wires	order No.	---	---
10-30 Vdc	PNP NO	3 wires	order No.	---	---
10-30 Vdc	PNP NC	3 wires	order No.	---	---
10-30 Vdc	NPN NO	3 wires	order No.	---	---
10-30 Vdc	NPN NC	3 wires	order No.	---	---
10-30 Vdc	PNP NO-NC	3 wires	order No.	---	---
10-30 Vdc	NPN NO-NC	3 wires	order No.	---	---
10-30 Vdc	NO-NC	2 wires	order No.	---	---
20-250 Vac/Vdc	NO	2 wires	order No.	---	---
20-250 Vac/Vdc	NC	2 wires	order No.	---	---
20-250 Vac/Vdc	NO	2/3wires	order No.	IS-18-A15-S2 95B060780	IS-18-A15-03 95B060770
Analog 0-20mA	-	3 wires	order No.	---	---
5+24 Vdc	NAMUR	2 wires	order No.	---	---

Nominal Voltage	20+250 Vac (50,60 Hz)	20+250 Vac (50,60 Hz)
Residual Ripple	< 10%	< 10%
Hysteresis	< 10%	< 10%
Max. Output Current	500 mA, inrush:1,5A	500 mA, inrush:1,5A
Min. Output Current	20 mA	20 mA
Residual Current	< 0,7 mA	< 0,7 mA
Voltage Drop	< 4 V (I=100mA)	< 4 V (I=100mA)
Operation Led	Yellow	Yellow
Switching Frequency	25 Hz	25 Hz
Start Up Delay	< 300 ms	< 300 ms
Repeability	5%	5%
Short Circuit Protection	Present (self-resetting)	Present (self-resetting)
Electric Protection	Against polarity reversal inductive loads	Against polarity reversal inductive loads
Temperature Limit	(-25 ... +70 °C)	(-25 ... +70 °C)
Protection Degree	IP67	IP67
Cable Length	---	2 m
Cable Section	---	2 x 0,25 mm <sup>2</sup>
Housing Material	Nickel-plated brass	Nickel-plated brass
Weight - Cable Output	---	145g
Weight - M12 Connector Output	95g	---

# INDUCTIVE AC M30

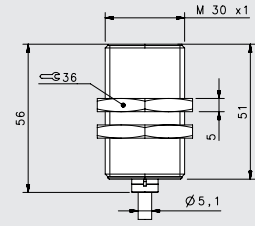
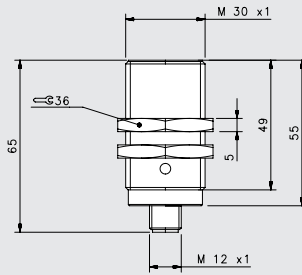

## STANDARD VAC

FLUSH

M12 conn

cable

### NOMINAL SWITCHING DISTANCE

				10 mm	10 mm
10-30 Vdc	PNP/NPN NO-NC	4 wires	order No.	---	---
10-30 Vdc	PNP NO	3 wires	order No.	---	---
10-30 Vdc	PNP NC	3 wires	order No.	---	---
10-30 Vdc	NPN NO	3 wires	order No.	---	---
10-30 Vdc	NPN NC	3 wires	order No.	---	---
10-30 Vdc	PNP NO-NC	3 wires	order No.	---	---
10-30 Vdc	NPN NO-NC	3 wires	order No.	---	---
10-30 Vdc	NO-NC	2 wires	order No.	---	---
20-250 Vac/Vdc	NO	2 wires	order No.	---	---
20-250 Vac/Vdc	NC	2 wires	order No.	---	---
20-250 Vac/Vdc	NO	2/3wires	order No.	IS-30-A15-S2 95B060820	IS-30-A15-03 95B060810
Analog 0-20mA	-	3 wires	order No.	---	---
5+24 Vdc	NAMUR	2 wires	order No.	---	---

Nominal Voltage	20+250 Vac (50,60 Hz)	20+250 Vac (50,60 Hz)
Residual Ripple	< 10%	< 10%
Hysteresis	< 10%	< 10%
Max. Output Current	500 mA, inrush:1,5A	500 mA, inrush:1,5A
Min. Output Current	20 mA	20 mA
Residual Current	< 0,7 mA	< 0,7 mA
Voltage Drop	< 4 V (I=100mA)	< 4 V (I=100mA)
Operation Led	Yellow	Yellow
Switching Frequency	25 Hz	25 Hz
Start Up Delay	< 300 ms	< 300 ms
Repeability	5%	5%
Short Circuit Protection	Present (self-resetting)	Present (self-resetting)
Electric Protection	Against polarity reversal inductive loads	Against polarity reversal inductive loads
Temperature Limit	(-25 ... +70 °C)	(-25 ... +70 °C)
Protection Degree	IP67	IP67
Cable Length	---	2 m
Cable Section	---	2 x 0,25 mm <sup>2</sup>
Housing Material	Nickel-plated brass	Nickel-plated brass
Weight - Cable Output	---	145g
Weight - M12 Connector Output	95g	---



# NAMUR

Stainless Steel housing

Short length

Operating distance 0.8 ... 15 mm

M12, M18

Cable, M8 or M12 connector

2 wires

IP67 protection

~M12/18/30 모델은 Diversey & ECOLAB 테스트(세제에 대한 부식)를 거친 제품입니다~



M12/18/30 FLUSH 모델은 ATEX 인증을 받은 제품입니다



pag  
08

BASIC

pag  
32

STAINLESS  
STEEL

pag  
46

METAL  
FACE

pag  
50

WELD FIELD  
IMMUNE

pag  
54

INDUCTIVE AC

pag  
60

NAMUR

pag  
70

SQUARE

pag  
76

CABLES,  
CONNECTORS  
& ACCESSORIES



# NAMUR

# NAMUR M5

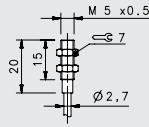

## NAMUR

FLUSH

cable

### NOMINAL SWITCHING DISTANCE

0,8 mm

10-30 Vdc	PNP/NPN NO-NC	4 wires	order No.	---
10-30 Vdc	PNP NO	3 wires	order No.	---
10-30 Vdc	PNP NC	3 wires	order No.	---
10-30 Vdc	NPN NO	3 wires	order No.	---
10-30 Vdc	NPN NC	3 wires	order No.	---
10-30 Vdc	PNP NO-NC	3 wires	order No.	---
10-30 Vdc	NPN NO-NC	3 wires	order No.	---
10-30 Vdc	NO-NC	2 wires	order No.	---
20-250 Vac/Vdc	NO	2 wires	order No.	---
20-250 Vac/Vdc	NC	2 wires	order No.	---
20-250 Vac/Vdc	NO	2/3wires	order No.	---
Analog 0-20mA	-	3 wires	order No.	---
5+24 Vdc	NAMUR	2 wires	order No.	IS-05-A20-03 95B065410

Nominal Voltage	6+ 12 V DC
Residual Ripple	---
Hysteresis	< 10%
Max. Output Current	< 3 mA (metal absent)
Min. Output Current	< 1 mA (metal present)
Residual Current	---
Voltage Drop	---
Operation Led	Yellow
Switching Frequency	2000 Hz
Start Up Delay	< 10 ms
Repeability	---
Short Circuit Protection	Present (self-resetting)
Electric Protection	Against polarity reversal inductive loads
Temperature Limit	(-25 ... +70 °C)
Protection Degree	IP67
Cable Length	2 m (PVC)
Cable Section	2x 0,15 mm <sup>2</sup>
Housing Material	Stainless-Steel
Weight - Cable Output	25g
Weight - M12 Connector Output	---

# NAMUR M6,5

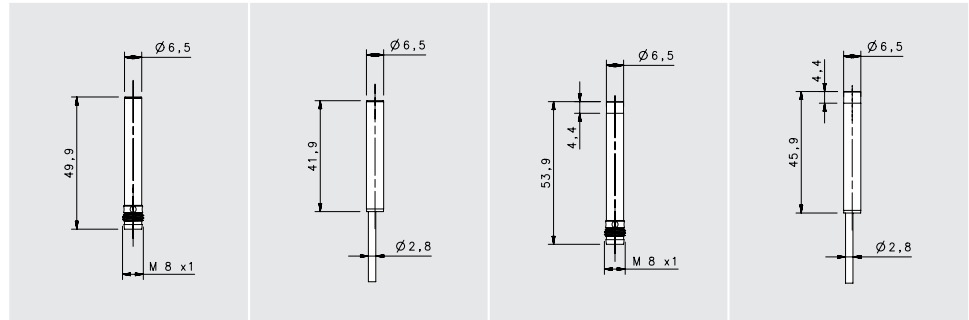

## NAMUR

FLUSH		NON FLUSH	
M8 conn	cable	M8 conn	cable

### NOMINAL SWITCHING DISTANCE

				FLUSH		NON FLUSH	
				1 mm	1 mm	2 mm	2 mm
10-30 Vdc	PNP/NPN NO-NC	4 wires	order No.	---	---	---	---
10-30 Vdc	PNP NO	3 wires	order No.	---	---	---	---
10-30 Vdc	PNP NC	3 wires	order No.	---	---	---	---
10-30 Vdc	NPN NO	3 wires	order No.	---	---	---	---
10-30 Vdc	NPN NC	3 wires	order No.	---	---	---	---
10-30 Vdc	PNP NO-NC	3 wires	order No.	---	---	---	---
10-30 Vdc	NPN NO-NC	3 wires	order No.	---	---	---	---
10-30 Vdc	NO-NC	2 wires	order No.	---	---	---	---
20-250 Vac/Vdc	NO	2 wires	order No.	---	---	---	---
20-250 Vac/Vdc	NC	2 wires	order No.	---	---	---	---
20-250 Vac/Vdc	NO	2/3 wires	order No.	---	---	---	---
Analog 0-20mA	-	3 wires	order No.	---	---	---	---
5+24 Vdc	NAMUR	2 wires	order No.	IS-65-A20-S1 95B066310	IS-65-A20-O3 95B066290	IS-65-C20-S1 95B066320	IS-65-C20-O3 95B066300

Nominal Voltage	7,7 +9 V DC	7,7 +9 V DC	7,7 +9 V DC	7,7 +9 V DC
Residual Ripple	< 10%	< 10%	< 10%	< 10%
Hysteresis	< 10%	< 10%	< 10%	< 10%
Max. Output Current	< 3 mA (metal absent)	< 3 mA (metal absent)	< 3 mA (metal absent)	< 3 mA (metal absent)
Min. Output Current	< 1 mA (metal present)	< 1 mA (metal present)	< 1 mA (metal present)	< 1 mA (metal present)
Residual Current	---	---	---	---
Voltage Drop	---	---	---	---
Operation Led	Yellow	Yellow	Yellow	Yellow
Switching Frequency	2000 Hz	2000 Hz	2000 Hz	2000 Hz
Start Up Delay	---	---	---	---
Repeability	< 3%	< 3%	< 3%	< 3%
Short Circuit Protection	Present (self-resetting)	Present (self-resetting)	Present (self-resetting)	Present (self-resetting)
Electric Protection	Against polarity reversal inductive loads	Against polarity reversal inductive loads	Against polarity reversal inductive loads	Against polarity reversal inductive loads
Temperature Limit	(-25 ... +60 °C)	(-25 ... +60 °C)	(-25 ... +60 °C)	(-25 ... +60 °C)
Protection Degree	IP67	IP67	IP67	IP67
Cable Length	---	2 m	---	2 m
Cable Section	---	2x 0,25 mm <sup>2</sup>	---	2 x 0,25 mm <sup>2</sup>
Housing Material	Stainless-Steel	Stainless-Steel	Stainless-Steel	Stainless-Steel
Weight - Cable Output	---	80 g	---	80 g
Weight - M12 Connector Output	40 g	---	40 g	---

# NAMUR M8

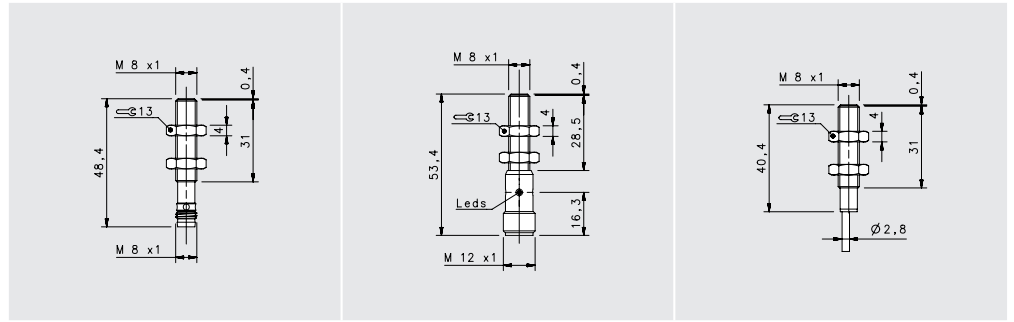

## NAMUR

### FLUSH

				M8 conn	M12 conn	cable
NOMINAL SWITCHING DISTANCE				1 mm	1 mm	1 mm
10-30 Vdc	PNP/NPN NO-NC	4 wires	order No.	---	---	---
10-30 Vdc	PNP NO	3 wires	order No.	---	---	---
10-30 Vdc	PNP NC	3 wires	order No.	---	---	---
10-30 Vdc	NPN NO	3 wires	order No.	---	---	---
10-30 Vdc	NPN NC	3 wires	order No.	---	---	---
10-30 Vdc	PNP NO-NC	3 wires	order No.	---	---	---
10-30 Vdc	NPN NO-NC	3 wires	order No.	---	---	---
10-30 Vdc	NO-NC	2 wires	order No.	---	---	---
20-250 Vac/Vdc	NO	2 wires	order No.	---	---	---
20-250 Vac/Vdc	NC	2 wires	order No.	---	---	---
20-250 Vac/Vdc	NO	2/3wires	order No.	---	---	---
Analog 0-20mA	-	3 wires	order No.	---	---	---
5+24 Vdc	NAMUR	2 wires	order No.	IS-08-A20-S1 95B066760	IS-08-A20-S2 95B066780	S-08-A20-03 95B066740

Nominal Voltage	7,7 + 9 V DC	7,7 + 9 V DC	7,7 + 9 V DC
Residual Ripple	< 10%	< 10%	< 10%
Hysteresis	< 10%	< 10%	< 10%
Max. Output Current	< 3 mA (metal absent)	< 3 mA (metal absent)	< 3 mA (metal absent)
Min. Output Current	< 1 mA (metal present)	< 1 mA (metal present)	< 1 mA (metal present)
Residual Current	---	---	---
Voltage Drop	---	---	---
Operation Led	Yellow	Yellow	Yellow
Switching Frequency	2000 Hz	2000 Hz	2000 Hz
Start Up Delay	---	---	---
Repeability	< 3%	< 3%	< 3%
Short Circuit Protection	Present (self-resetting)	Present (self-resetting)	Present (self-resetting)
Electric Protection	Against polarity reversal inductive loads	Against polarity reversal inductive loads	Against polarity reversal inductive loads
Temperature Limit	(-25 ... +60 °C)	(-25 ... +60 °C)	(-25 ... +60 °C)
Protection Degree	IP67	IP67	IP67
Cable Length	---	---	2 m
Cable Section	---	---	2x 0,25 mm <sup>2</sup>
Housing Material	Stainless-Steel	Stainless-Steel	Stainless-Steel
Weight - Cable Output	---	---	80 g
Weight - M12 Connector Output	35g	55g	---



# NAMUR M12

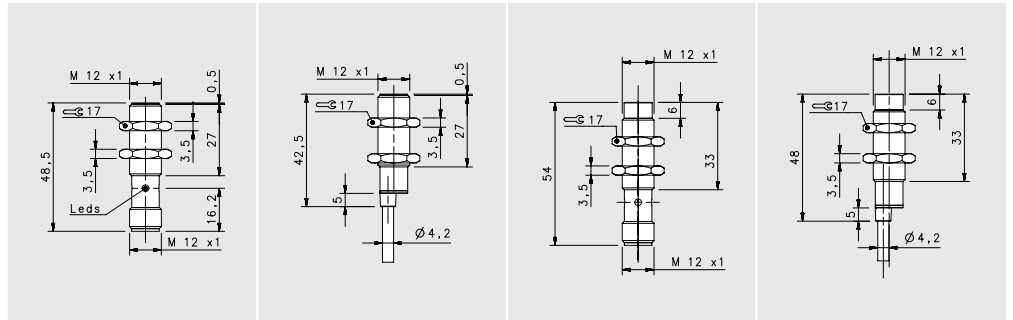

## NAMUR

				FLUSH		NON FLUSH	
				M12 conn	cable	M12 conn	cable
				2 mm	2 mm	4mm	4mm
NOMINAL SWITCHING DISTANCE							
10-30 Vdc	PNP/NPN NO-NC	4 wires	order No.	---	---	---	---
10-30 Vdc	PNP NO	3 wires	order No.	---	---	---	---
10-30 Vdc	PNP NC	3 wires	order No.	---	---	---	---
10-30 Vdc	NPN NO	3 wires	order No.	---	---	---	---
10-30 Vdc	NPN NC	3 wires	order No.	---	---	---	---
10-30 Vdc	PNP NO-NC	3 wires	order No.	---	---	---	---
10-30 Vdc	NPN NO-NC	3 wires	order No.	---	---	---	---
10-30 Vdc	NO-NC	2 wires	order No.	---	---	---	---
20-250 Vac/Vdc	NO	2 wires	order No.	---	---	---	---
20-250 Vac/Vdc	NC	2 wires	order No.	---	---	---	---
20-250 Vac/Vdc	NO	2/3wires	order No.	---	---	---	---
Analog 0-20mA	-	3 wires	order No.	---	---	---	---
5+24 Vdc	NAMUR	2 wires	order No.	IS-12-A20-S2 95B064180	IS-12-A20-O3 95B064160	IS-12-C20-S2 95B064190	IS-12-C20-O3 95B064170

Nominal Voltage	7,7+9 V DC	7,7+9 V DC	7,7+9 V DC	7,7+9 V DC
Residual Ripple	< 10%	< 10%	< 10%	< 10%
Hysteresis	< 10%	< 10%	< 10%	< 10%
Max. Output Current	< 3 mA (metal absent)	< 3 mA (metal absent)	< 3 mA (metal absent)	< 3 mA (metal absent)
Min. Output Current	< 1 mA (metal present)	< 1 mA (metal present)	< 1 mA (metal present)	< 1 mA (metal present)
Residual Current	---	---	---	---
Voltage Drop	---	---	---	---
Operation Led	Yellow	Yellow	Yellow	Yellow
Switching Frequency	2000 Hz	2000 Hz	2000 Hz	2000 Hz
Start Up Delay	---	---	---	---
Repeability	< 3%	< 3%	< 3%	< 3%
Short Circuit Protection	Present (self-resetting)	Present (self-resetting)	Present (self-resetting)	Present (self-resetting)
Electric Protection	Against polarity reversal inductive loads	Against polarity reversal inductive loads	Against polarity reversal inductive loads	Against polarity reversal inductive loads
Temperature Limit	(-25 ... +60 °C)	(-25 ... +60 °C)	(-25 ... +60 °C)	(-25 ... +60 °C)
Protection Degree	IP67	IP67	IP67	IP67
Cable Length	---	2 m	---	2 m
Cable Section	---	2 x 0,25 mm <sup>2</sup>	---	2 x 0,25 mm <sup>2</sup>
Housing Material	Stainless-Steel	Stainless-Steel	Stainless-Steel	Stainless-Steel
Weight - Cable Output	---	110 g	---	110 g
Weight - M12 Connector Output	60 g	---	60 g	---

# NAMUR M18

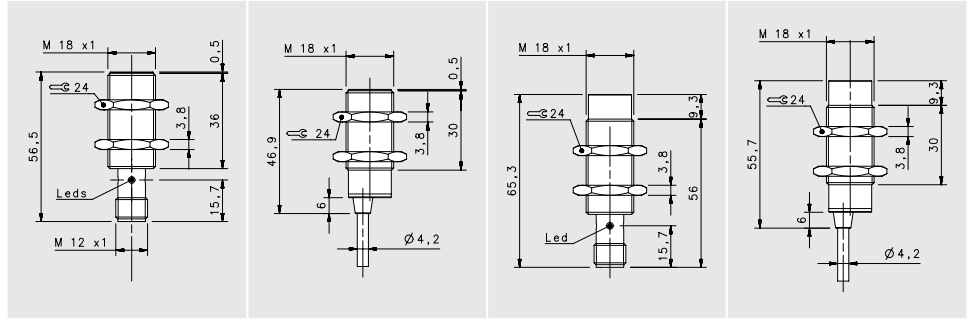

## NAMUR

FLUSH	NON FLUSH
-------	-----------

NOMINAL SWITCHING DISTANCE				FLUSH		NON FLUSH	
				M12 conn 5mm	cable 5mm	M12 conn 8mm	cable 8mm
10-30 Vdc	PNP/NPN NO-NC	4 wires	order No.	---	---	---	---
10-30 Vdc	PNP NO	3 wires	order No.	---	---	---	---
10-30 Vdc	PNP NC	3 wires	order No.	---	---	---	---
10-30 Vdc	NPN NO	3 wires	order No.	---	---	---	---
10-30 Vdc	NPN NC	3 wires	order No.	---	---	---	---
10-30 Vdc	PNP NO-NC	3 wires	order No.	---	---	---	---
10-30 Vdc	NPN NO-NC	3 wires	order No.	---	---	---	---
10-30 Vdc	NO-NC	2 wires	order No.	---	---	---	---
20-250 Vac/Vdc	NO	2 wires	order No.	---	---	---	---
20-250 Vac/Vdc	NC	2 wires	order No.	---	---	---	---
20-250 Vac/Vdc	NO	2/3 wires	order No.	---	---	---	---
Analog 0-20mA	-	3 wires	order No.	---	---	---	---
5+24 Vdc	NAMUR	2 wires	order No.	IS-18-A20-S2 95B064380	IS-18-A20-03 95B064360	IS-18-C20-S2 95B064390	IS-18-C20-03 95B064370

Nominal Voltage	7,7 +9 V DC	7,7 +9 V DC	7,7 +9 V DC	7,7 +9 V DC
Residual Ripple	< 10%	< 10%	< 10%	< 10%
Hysteresis	< 10%	< 10%	< 10%	< 10%
Max. Output Current	< 3 mA (metal absent)	< 3 mA (metal absent)	< 3 mA (metal absent)	< 3 mA (metal absent)
Min. Output Current	< 1 mA (metal present)	< 1 mA (metal present)	< 1 mA (metal present)	< 1 mA (metal present)
Residual Current	---	---	---	---
Voltage Drop	---	---	---	---
Operation Led	Yellow	Yellow	Yellow	Yellow
Switching Frequency	1000 Hz	1000 Hz	1000 Hz	1000 Hz
Start Up Delay	---	---	---	---
Repeability	< 3%	< 3%	< 3%	< 3%
Short Circuit Protection	Present (self-resetting)	Present (self-resetting)	Present (self-resetting)	Present (self-resetting)
Electric Protection	Against polarity reversal inductive loads	Against polarity reversal inductive loads	Against polarity reversal inductive loads	Against polarity reversal inductive loads
Temperature Limit	(-25 ... +60 °C)	(-25 ... +60 °C)	(-25 ... +60 °C)	(-25 ... +60 °C)
Protection Degree	IP67	IP67	IP67	IP67
Cable Length	---	2 m	---	2 m
Cable Section	---	2 x 0,25 mm <sup>2</sup>	---	2 x 0,25 mm <sup>2</sup>
Housing Material	Stainless-Steel	Stainless-Steel	Stainless-Steel	Stainless-Steel
Weight - Cable Output	---	145g	---	145g
Weight - M12 Connector Output	95g	---	95g	---

# NAMUR M30

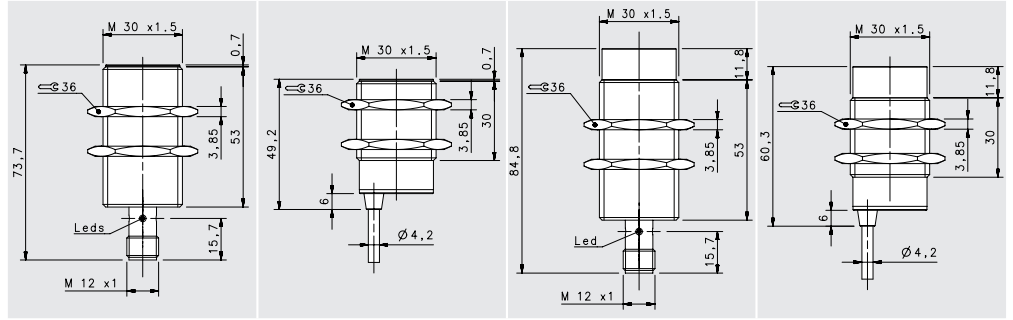

## NAMUR

### NOMINAL SWITCHING DISTANCE

				FLUSH		NON FLUSH	
				M12 conn	cable	M12 conn	cable
				10mm	10mm	15mm	15mm
10-30 Vdc	PNP/NPN NO-NC	4 wires	order No.	---	---	---	---
10-30 Vdc	PNP NO	3 wires	order No.	---	---	---	---
10-30 Vdc	PNP NC	3 wires	order No.	---	---	---	---
10-30 Vdc	NPN NO	3 wires	order No.	---	---	---	---
10-30 Vdc	NPN NC	3 wires	order No.	---	---	---	---
10-30 Vdc	PNP NO-NC	3 wires	order No.	---	---	---	---
10-30 Vdc	NPN NO-NC	3 wires	order No.	---	---	---	---
10-30 Vdc	NO-NC	2 wires	order No.	---	---	---	---
20-250 Vac/Vdc	NO	2 wires	order No.	---	---	---	---
20-250 Vac/Vdc	NC	2 wires	order No.	---	---	---	---
20-250 Vac/Vdc	NO	2/3wires	order No.	---	---	---	---
Analog 0-20mA	-	3 wires	order No.	---	---	---	---
5+24 Vdc	NAMUR	2 wires	order No.	IS-30-A20-S2 95B064630	IS-30-A20-O3 95B064610	IS-30-C20-S2 95B064640	IS-30-C20-O3 95B064620

Nominal Voltage	7,7+9 V DC	7,7+9 V DC	7,7+9 V DC	7,7+9 V DC
Residual Ripple	< 10%	< 10%	< 10%	< 10%
Hysteresis	< 10%	< 10%	< 10%	< 10%
Max. Output Current	< 3 mA (metal absent)	< 3 mA (metal absent)	< 3 mA (metal absent)	< 3 mA (metal absent)
Min. Output Current	< 1 mA (metal present)	< 1 mA (metal present)	< 1 mA (metal present)	< 1 mA (metal present)
Residual Current	---	---	---	---
Voltage Drop	---	---	---	---
Operation Led	Yellow	Yellow	Yellow	Yellow
Switching Frequency	500 Hz	500 Hz	500 Hz	500 Hz
Start Up Delay	---	---	---	---
Repeability	< 3%	< 3%	< 3%	< 3%
Short Circuit Protection	Present (self-resetting)	Present (self-resetting)	Present (self-resetting)	Present (self-resetting)
Electric Protection	Against polarity reversal inductive loads	Against polarity reversal inductive loads	Against polarity reversal inductive loads	Against polarity reversal inductive loads
Temperature Limit	(-25 ... +60 °C)	(-25 ... +60 °C)	(-25 ... +60 °C)	(-25 ... +60 °C)
Protection Degree	IP67	IP67	IP67	IP67
Cable Length	---	2 m	---	2 m
Cable Section	---	2 x 0,25 mm <sup>2</sup>	---	2 x 0,25 mm <sup>2</sup>
Housing Material	Stainless-Steel	Stainless-Steel	Stainless-Steel	Stainless-Steel
Weight - Cable Output	---	210 g	---	210 g
Weight - M12 Connector Output	170 g	---	170 g	---



# SQUARE

PBT (resin) or Nickel-plated Brass housing

Operating distance 1.5 ... 15 mm

40x40 mm or 8x8 mm dimension

Cable, M8 connector or Terminal Block

2 or 3 wires

PNP, PNP/NPN, NO, NC, NO/NC

IP67

“M12/18/30 모델은 Diversey & ECOLAB 테스트(세제에 대한 부식)를 거친 제품입니다”



M12/18/30 FLUSH 모델은 ATEX 인증을 받은 제품입니다



pag  
08

BASIC

pag  
32

STAINLESS  
STEEL

pag  
46

METAL  
FACE

pag  
50

WELD FIELD  
IMMUNE

pag  
54

INDUCTIVE AC

pag  
60

NAMUR

pag  
70

SQUARE

pag  
76

CABLES,  
CONNECTORS  
& ACCESSORIES



# SQUARE

# SQUARE 40X40

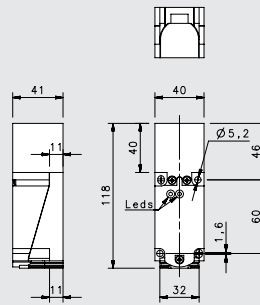
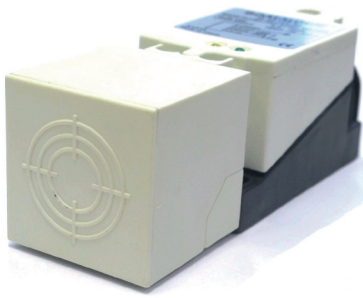

## 40X40

				FLUSH		NON FLUSH	
				Terminal Block		Terminal Block	
NOMINAL SWITCHING DISTANCE				15 mm		30mm	
10-30 Vdc	PNP/NPN NO-NC	4 wires	order No.	---	---	---	---
10-30 Vdc	PNP NO	3 wires	order No.	---	---	---	---
10-30 Vdc	PNP NC	3 wires	order No.	---	---	---	---
10-30 Vdc	NPN NO	3 wires	order No.	---	---	---	---
10-30 Vdc	NPN NC	3 wires	order No.	---	---	---	---
10-30 Vdc	PNP NO-NC	3 wires	order No.	IS-40-W5-S3 95B065240	IS-40-Y5-S3 95B065280		
10-30 Vdc	NPN NO-NC	3 wires	order No.	IS-40-W6-S3 95B065230	IS-40-Y6-S3 95B065270		
10-30 Vdc	NO-NC	2 wires	order No.	---	---		
20-250 Vac/Vdc	NO	2 wires	order No.	---	---		
20-250 Vac/Vdc	NC	2 wires	order No.	---	---		
20-250 Vac/Vdc	NO	2/3wires	order No.	---	---		
Analog 0-20mA	-	3 wires	order No.	---	---		
5+24 Vdc	NAMUR	2 wires	order No.	---	---		
Nominal Voltage				10-30 Vdc	10-30 Vdc		
Residual Ripple				< 10%	< 10%		
Hysteresis				< 15% (Sr)	< 15% (Sr)		
Max. Output Current				200mA	200mA		
Min. Output Current				---	---		
Residual Current				< 0,01 mA	< 0,01 mA		
Voltage Drop				< 1,5V	< 1,5V		
Operation Led				YES	YES		
Switching Frequency				100 Hz	100 Hz		
Start Up Delay				---	---		
Repeability				< 1.0% (Sr)	< 1.0% (Sr)		
Short Circuit Protection				Present (self-resetting)	Present (self-resetting)		
Electric Protection				Against polarity reversal inductive loads	Against polarity reversal inductive loads		
Temperature Limit				(-25 ... +75C)	(-25 ... +75 °C)		
Protection Degree				IP67	IP67		
Cable Length				---	---		
Cable Section				---	---		
Housing Material				PBT ( RESIN)	PBT ( RESIN)		
Weight - Cable Output				---	---		
Weight - M12 Connector Output				262g	262g		



# SQUARE 40X40

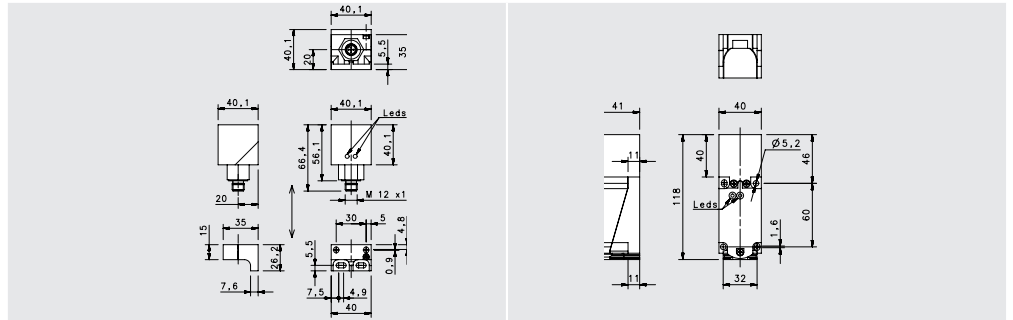

SHORT	ANALOG OUTPUT
FLUSH	NON FLUSH

M12 conn.

Terminal Block

## NOMINAL SWITCHING DISTANCE

				15mm	7-20mm
10-30 Vdc	PNP/NPN NO-NC	4 wires	order No.	---	---
10-30 Vdc	PNP NO	3 wires	order No.	---	---
10-30 Vdc	PNP NC	3 wires	order No.	---	---
10-30 Vdc	NPN NO	3 wires	order No.	---	---
10-30 Vdc	NPN NC	3 wires	order No.	---	---
10-30 Vdc	PNP NO-NC	3 wires	order No.	IS-40-X5-S2 95B065320	---
10-30 Vdc	NPN NO-NC	3 wires	order No.	IS-40-X6-S2 95B065310	---
10-30 Vdc	NO-NC	2 wires	order No.	---	---
20-250 Vac/Vdc	NO	2 wires	order No.	---	---
20-250 Vac/Vdc	NC	2 wires	order No.	---	---
20-250 Vac/Vdc	NO	2/3wires	order No.	---	---
Analog 0-20mA	-	3 wires	order No.	---	IS-40-C11-S3 95B065330
5+24 Vdc	NAMUR	2 wires	order No.	---	---

Nominal Voltage	10-30 Vdc	18-30 Vdc
Residual Ripple	< 10%	< 10%
Hysteresis	< 15% (Sr)	< 10% (Sr)
Max. Output Current	200mA	0-20mA/200 Max.
Min. Output Current	---	---
Residual Current	< 0,01mA	---
Voltage Drop	< 1,5V	---
Operation Led	YES	---
Switching Frequency	100 Hz	100 Hz
Start Up Delay	---	---
Repeability	< 1.0% (Sr)	5% (Sr) Temperature Drift
Short Circuit Protection	Present (self-resetting)	Present (self-resetting)
Electric Protection	Against polarity reversal inductive loads	Against polarity reversal inductive loads
Temperature Limit	(-25... +70 °C)	(-25 ... +70 °C)
Protection Degree	IP67	IP67
Cable Length	---	---
Cable Section	---	---
Housing Material	PBT ( RESIN)	PBT ( RESIN)
Weight - Cable Output	---	---
Weight - M12 Connector Output	170 g	242g

# SQUARE 8X8

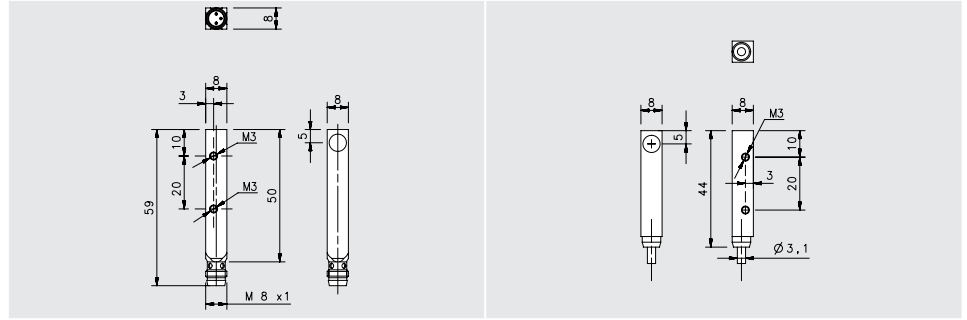
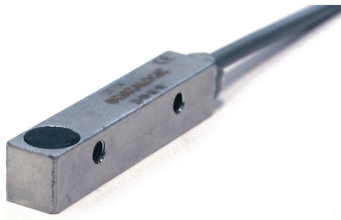

## SHORT

### FLUSH

M8 conn

cable

1,5mm

1,5mm

#### NOMINAL SWITCHING DISTANCE

				M8 conn 1,5mm	cable 1,5mm
10-30 Vdc	PNP/NPN NO-NC	4 wires	order No.	---	---
10-30 Vdc	PNP NO	3 wires	order No.	IS-88-Q1-S1 95B060840	IS-88-Q1-03 95B060830
10-30 Vdc	PNP NC	3 wires	order No.	---	---
10-30 Vdc	NPN NO	3 wires	order No.	---	---
10-30 Vdc	NPN NC	3 wires	order No.	---	---
10-30 Vdc	PNP NO-NC	3 wires	order No.	---	---
10-30 Vdc	NPN NO-NC	3 wires	order No.	---	---
10-30 Vdc	NO-NC	2 wires	order No.	---	---
20-250 Vac/Vdc	NO	2 wires	order No.	---	---
20-250 Vac/Vdc	NC	2 wires	order No.	---	---
20-250 Vac/Vdc	NO	2/3 wires	order No.	---	---
Analog 0-20mA	-	3 wires	order No.	---	---
5+24 Vdc	NAMUR	2 wires	order No.	---	---

Nominal Voltage	10-30 Vdc	10-30 Vdc
Residual Ripple	< 10%	< 10%
Hysteresis	< 10% (Sr)	< 10% (Sr)
Max. Output Current	200mA	200mA
Min. Output Current	---	---
Residual Current	---	---
Voltage Drop	< 1,2V	< 1,2V
Operation Led	Yellow	Yellow
Switching Frequency	500 Hz	500 Hz
Start Up Delay	75 ms	75 ms
Repeability	< 3%	< 3%
Short Circuit Protection	Present (self-resetting)	Present (self-resetting)
Electric Protection	Against polarity reversal inductive loads	Against polarity reversal inductive loads
Temperature Limit	(-25 ... +70 °C)	(-25 ... +70 °C)
Protection Degree	IP67	IP67
Cable Length	---	2 m
Cable Section	---	3x0,14mm <sup>2</sup>
Housing Material	nickel-plated brass	nickel-plated brass
Weight - Cable Output	---	80 g
Weight - M12 Connector Output	40 g	---

# CABLES, CONNECTORS & ACCESSORIES

2, 3, 4 wires

M12, M8 connector

Axial or radial 90°

Shielded or unshielded

Double key

A.C. cable

3, 5, 7, 10, 15, 25m cable

“M12/18/30 모델은 Diversey & ECOLAB 테스트(세제에 대한 부식)를 거친 제품입니다”



M12/18/30 FLUSH 모델은 ATEX 인증을 받은 제품입니다



pag  
08

BASIC

pag  
32

STAINLESS  
STEEL

pag  
46

METAL  
FACE

pag  
50

WELD FIELD  
IMMUNE

pag  
54

INDUCTIVE AC

pag  
60

NAMUR

pag  
70

SQUARE

# CABLES, CONNECTORS & ACCESSORIES

pag  
76

CABLES,  
CONNECTORS  
& ACCESSORIES

# CABLES, CONNECTORS & ACCESSORIES

## 2-3 POLES - AC CABLES

CONNECTOR	TYPE	ORIENTATION	LENGTH	MATERIAL	CODING	ORDER No.
M12	"shielded AC sensors"	axial, double key	2m	PVC	CS-A1-21-R-03	95A252880
			5m		CS-A1-21-R-05	95A252890

### WIRING DIAGRAMS

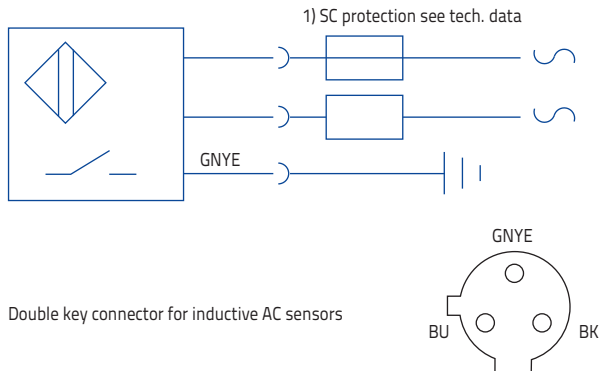

### WIRING DIAGRAMS

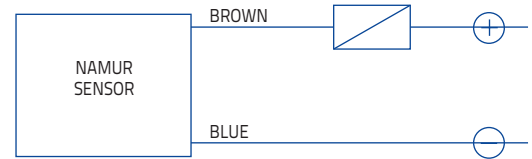

### WIRING DIAGRAMS

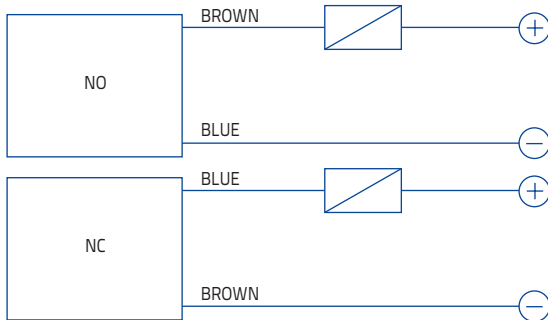

**WARNING:** The load can be indifferently connected in series to the blue wire or to the brown wire to simulate NPN or PNP functioning logic.

### CONNECTION WITH CONNECTOR M12

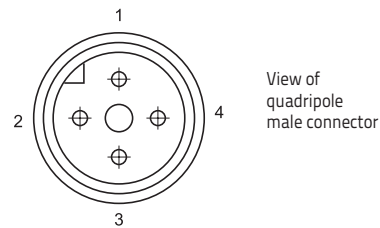

#### CONTACTS CONFIGURATION

Available	Contacts numbers			
	1	2	3	4
NAMUR	+		-	

### CONNECTION WITH CONNECTOR M12

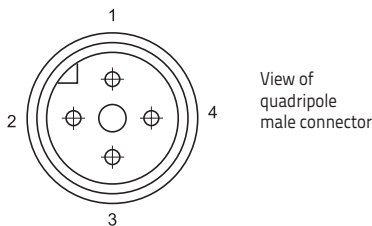

#### CONTACTS CONFIGURATION

Available	Contacts numbers			
	1	2	3	4
NO	+		-	
NC	-		+	

### CONNECTION WITH CONNECTOR M8

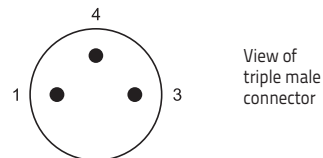

#### CONTACTS CONFIGURATION

Available	Contacts numbers		
	1	3	4
NAMUR	+	-	

### 3 POLES

CONNECTOR	TYPE	ORIENTATION	LENGTH	MATERIAL	CODING	ORDER No.				
M12	shielded	axial	3m	PVC	CS-A1-01-G-03	95A251290				
			5m		CS-A1-01-G-05	95A251300				
			7m		CS-A1-01-G-07	95A251320				
			10m		CS-A1-01-G-10	95A251340				
		radial 90°	3m		CS-A2-01-G-03	95A251200				
			5m		CS-A2-01-G-05	95A251210				
			7m		CS-A2-01-G-07	95A251220				
			10m		CS-A2-01-G-10	95A251230				
		radial 90° + LED	5m		CS-A2-11-G-05	95A251310				
			10m		CS-A2-11-G-10	95A251330				
			M8		shielded	axial	3m	PVC	CS-B1-01-G-03	95A251490
							5m	PVC	CS-B1-01-G-05	95A251510
2m	PUR	CS-B1-01-R-02		95A251580						
5m		CS-B1-01-R-05		95A251600						
radial 90°	3m	PVC		CS-B2-01-G-03		95A251500				
	5m	PVC		CS-B2-01-G-05		95A251520				
	2m	PUR	CS-B2-01-R-02	95A251590						
5m	CS-B2-01-R-05		95A251610							

#### CONNECTION WITH CONNECTOR M12

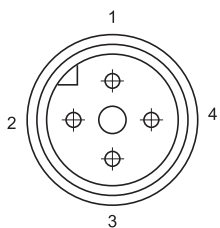

View of quadripole male connector

##### CONTACTS CONFIGURATION

Available	Contacts numbers			
	1	2	3	4
(NO or NC)	+		-	NO/NC

#### WIRING DIAGRAMS

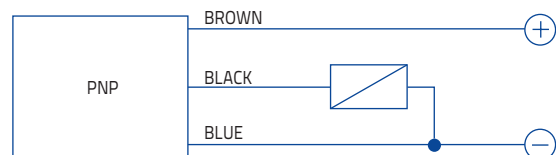
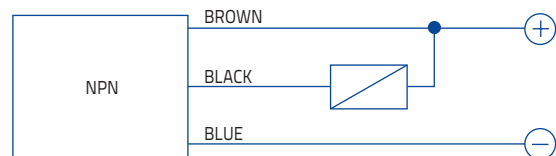

#### CONNECTION WITH CONNECTOR M8

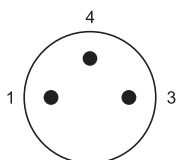

View of triple male connector

##### CONTACTS CONFIGURATION

Available	Contacts numbers		
	1	3	4
(NO or NC)	+	-	NO/NC

# CABLES, CONNECTORS & ACCESSORIES

## 4 POLES

CONNECTOR	TYPE	ORIENTATION	LENGTH	MATERIAL	CODING	ORDER No.		
M12	shielded	axial	3m	PVC	CS-A1-02-G-03	95A251380		
			5m		CS-A1-02-G-05	95A251270		
			7m		CS-A1-02-G-07	95A251280		
			10m		CS-A1-02-G-10	95A251390		
			2 m		PUR	CS-A1-02-R-02	95A251540	
		5m	CS-A1-02-R-05	95A251560				
		radial 90°	PVC	3m	CS-A2-02-G-03	95A251360		
				5m	CS-A2-02-G-05	95A251240		
				7m	CS-A2-02-G-07	95A251245		
				10m	CS-A2-02-G-10	95A251260		
	2 m			PUR	CS-A2-02-R-02	95A251550		
	5m	CS-A2-02-R-05	95A251570					
	radial 90° + LED	PVC	3m	CS-A2-12-G-03	95A251400			
			5m	CS-A2-12-G-05	95A251350			
			10m	CS-A2-12-G-10	95A251370			
			"unshielded UL2464"	axial	PVC	3m	CS-A1-02-U-03	95ASE1120
						5m	CS-A1-02-U-05	95ASE1130
	10m	CS-A1-02-U-10				95ASE1140		
	15m	CS-A1-02-U-15				95ASE1150		
	25m	CS-A1-02-U-25				95ASE1160		
M8	shielded	axial	PVC	3m	CS-B1-02-G-03	95A251420		
				5m	CS-B1-02-G-05	95A251430		
				7m	CS-B1-02-G-07	95A251440		
				10m	CS-B1-02-G-10	95A251480		
				2 m	PUR	CS-B1-02-R-02	95A251620	
		5m	CS-B1-02-R-05	95A251640				
		radial 90°	PVC	3m	CS-B2-02-G-03	95A251450		
				5m	CS-B2-02-G-05	95A251460		
				7m	CS-B2-02-G-07	95A251470		
				10m	CS-B2-02-G-10	95A251530		
	2 m			PUR	CS-B2-02-R-02	95A251630		
	5m	CS-B2-02-R-05	95A251650					

## WIRING DIAGRAMS

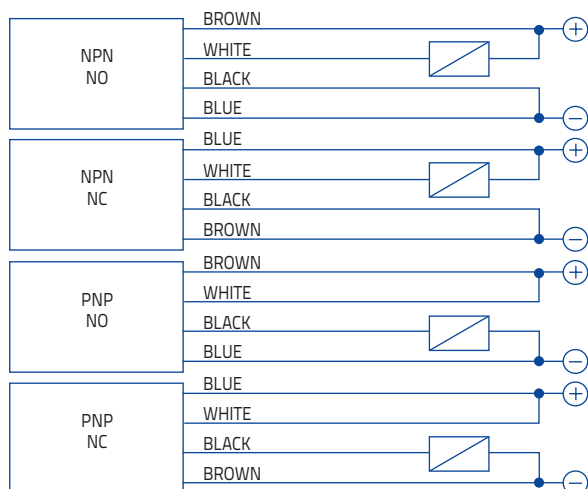

Thanks to the output status which is not paired with the rest of the circuit, the sensors of this kind of availability give enormous advantages, such as the possibility of obtaining the four output configurations (NPN-NO, NPN-NC, PNP-NO, PNP-NC) on the same model.

## CONNECTION WITH CONNECTOR M12

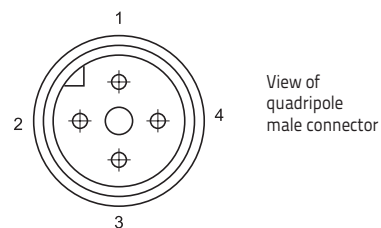

Output	CONTACTS CONFIGURATION			
	Contacts numbers			
	1	2	3	4
NPN NO	+	NO	-	-
NPN NC	-	NC	+	-
PNP NO	+	+	-	NO
PNP NC	-	+	+	NC

# CONNECTOR

CONNECTOR	TYPE	ORIENTATION	LENGTH	MATERIAL	CODING	ORDER No.
M12	connector	axial	FEMALE	PVC, gold-nickel-plated brass	CS-A1-02-B-NC	G5085002
		radial			CS-A2-02-B-NC	G5085003

## RADIAL M12

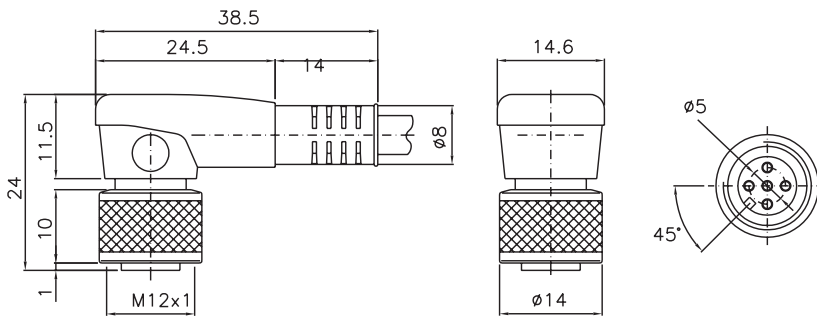

## AXIAL M12

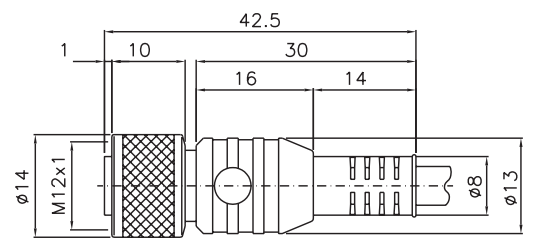

## RADIAL M8

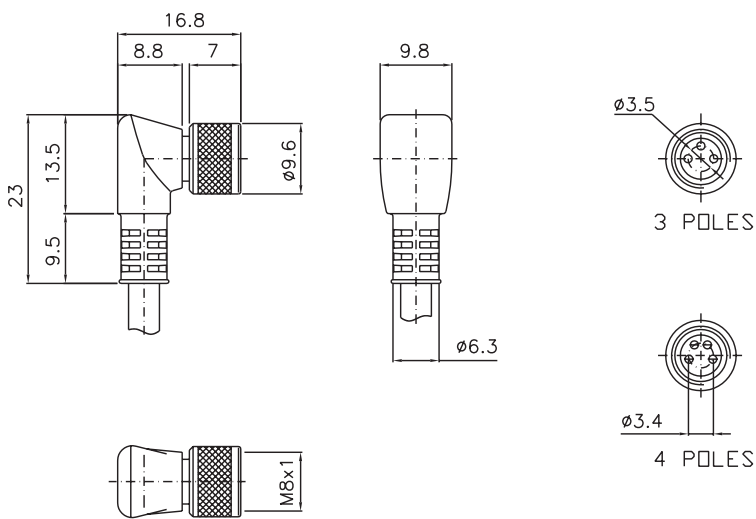

## AXIAL M8

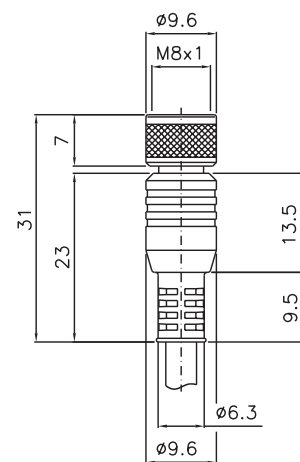

# CABLES, CONNECTORS & ACCESSORIES

## ACCESSORIES SELECTION AND ORDER INFORMATION

CONNECTOR	TYPE	MATERIAL	CODING	ORDER No.
M12	fixing bracket	Stainless Steel	ST1218	95ACC3340
M18	fixing bracket	Stainless Steel	ST1218	95ACC3340
M30	fixing bracket	Stainless Steel	ST1830	95ACC3350

### ST1218

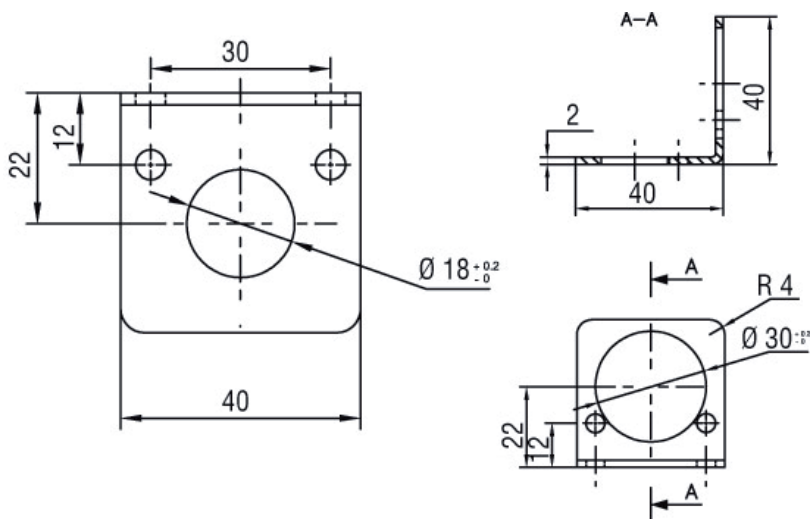

### ST1830

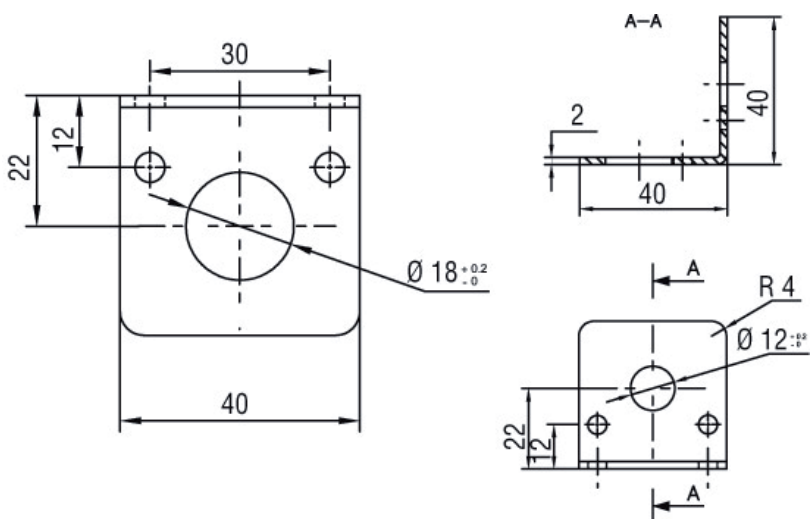



# CABLES, CONNECTORS & ACCESSORIES

## MODEL SELECTION AND ORDER INFORMATION

M4, M5, M6,5			
SENSOR	Order No.	Category	Pag.
IS-04-A1-03	95B061011	STAINLESS STEEL	34
IS-04-A3-03	95B061001	STAINLESS STEEL	34
IS-05-A1-03	95B061041	BASIC	35
IS-05-A1-S1	95B061051	BASIC	35
IS-05-A20-03	95B065410	NAMUR	62
IS-05-A3-03	95B061021	BASIC	35
IS-05-A3-S1	95B061031	BASIC	35
IS-05-A4-03	95B065420	BASIC	35
IS-05-E3-03	95B065400	BASIC	35
IS-65-A1-03	95B064730	BASIC	10
IS-65-A1-S1	95B066050	BASIC	10
IS-65-A20-03	95B066290	NAMUR	63
IS-65-A20-S1	95B066310	NAMUR	63
IS-65-A2-03	95B064770	BASIC	10
IS-65-A2-S1	95B066090	BASIC	10
IS-65-A3-03	95B064650	BASIC	10
IS-65-A3-S1	95B064970	BASIC	10
IS-65-A4-03	95B064690	BASIC	10
IS-65-A4-S1	95B066010	BASIC	10
IS-65-B1-03	95B064750	BASIC	11
IS-65-B1-S1	95B066070	BASIC	11
IS-65-B2-03	95B064790	BASIC	11
IS-65-B2-S1	95B066110	BASIC	11
IS-65-B3-03	95B064670	BASIC	11
IS-65-B3-S1	95B064990	BASIC	11
IS-65-B4-03	95B064710	BASIC	11
IS-65-B4-S1	95B066030	BASIC	11
IS-65-C1-03	95B064890	BASIC	10
IS-65-C1-S1	95B066210	BASIC	10
IS-65-C20-03	95B066300	NAMUR	63
IS-65-C20-S1	95B066320	NAMUR	63
IS-65-C2-03	95B064930	BASIC	10
IS-65-C2-S1	95B066250	BASIC	10
IS-65-C3-03	95B064810	BASIC	10
IS-65-C3-S1	95B066130	BASIC	10
IS-65-C4-03	95B064850	BASIC	10
IS-65-C4-S1	95B066170	BASIC	10
IS-65-D1-03	95B064910	BASIC	11
IS-65-D1-S1	95B066230	BASIC	11
IS-65-D2-03	95B064950	BASIC	11
IS-65-D2-S1	95B066270	BASIC	11
IS-65-D3-03	95B064830	BASIC	11
IS-65-D3-S1	95B066150	BASIC	11
IS-65-D4-03	95B064870	BASIC	11
IS-65-D4-S1	95B066190	BASIC	11
IS-65-G1-03	95B064740	BASIC	12
IS-65-G1-S1	95B066060	BASIC	12
IS-65-G2-03	95B064780	BASIC	12
IS-65-G2-S1	95B066100	BASIC	12
IS-65-G3-03	95B064660	BASIC	12
IS-65-G3-S1	95B064980	BASIC	12
IS-65-G4-03	95B064700	BASIC	12
IS-65-G4-S1	95B066020	BASIC	12
IS-65-H1-03	95B064900	BASIC	13
IS-65-H1-S1	95B066220	BASIC	13
IS-65-H2-03	95B064940	BASIC	13
IS-65-H2-S1	95B066260	BASIC	13
IS-65-H3-03	95B064820	BASIC	13
IS-65-H3-S1	95B066140	BASIC	13

IS-65-H4-03	95B064860	BASIC	13
IS-65-H4-S1	95B066180	BASIC	13
IS-65-M1-03	95B064760	STAINLESS STEEL	36
IS-65-M1-S1	95B066080	STAINLESS STEEL	36
IS-65-M2-03	95B064800	STAINLESS STEEL	36
IS-65-M2-S1	95B066120	STAINLESS STEEL	36
IS-65-M3-03	95B064680	STAINLESS STEEL	36
IS-65-M3-S1	95B066000	STAINLESS STEEL	36
IS-65-M4-03	95B064720	STAINLESS STEEL	36
IS-65-M4-S1	95B066040	STAINLESS STEEL	36
IS-65-N1-03	95B064920	STAINLESS STEEL	37
IS-65-N1-S1	95B066240	STAINLESS STEEL	37
IS-65-N2-03	95B064960	STAINLESS STEEL	37
IS-65-N2-S1	95B066280	STAINLESS STEEL	37
IS-65-N3-03	95B064840	STAINLESS STEEL	37
IS-65-N3-S1	95B066160	STAINLESS STEEL	37
IS-65-N4-03	95B064880	STAINLESS STEEL	37
IS-65-N4-S1	95B066200	STAINLESS STEEL	37

M8			
SENSOR	Order No.	Category	Pag.
IS-08-A1-03	95B061121	BASIC	14
IS-08-A1-S1	95B061141	BASIC	14
IS-08-A1-S2	95B061131	BASIC	14
IS-08-A20-03	95B066740	NAMUR	64
IS-08-A20-03	95B066760	NAMUR	64
IS-08-A20-S1	95B066780	NAMUR	64
IS-08-A2-03	95B061151	BASIC	14
IS-08-A2-S1	95B061171	BASIC	14
IS-08-A2-S2	95B061161	BASIC	14
IS-08-A3-03	95B061061	BASIC	14
IS-08-A3-S1	95B061081	BASIC	14
IS-08-A3-S2	95B061071	BASIC	14
IS-08-A4-03	95B061091	BASIC	14
IS-08-A4-S1	95B061111	BASIC	14
IS-08-A4-S2	95B061101	BASIC	14
IS-08-B1-03	95B061921	BASIC	16
IS-08-B1-S1	95B066860	BASIC	16
IS-08-B1-S2	95B066590	BASIC	16
IS-08-B2-03	95B061951	BASIC	16
IS-08-B2-S1	95B066890	BASIC	16
IS-08-B2-S2	95B066620	BASIC	16
IS-08-B3-03	95B061861	BASIC	16
IS-08-B3-S1	95B066810	BASIC	16
IS-08-B3-S2	95B066530	BASIC	16
IS-08-B4-03	95B061891	BASIC	16
IS-08-B4-S1	95B066830	BASIC	16
IS-08-B4-S2	95B066560	BASIC	16
IS-08-C1-03	95B061521	BASIC	15
IS-08-C1-S1	95B061541	BASIC	15
IS-08-C1-S2	95B061531	BASIC	15
IS-08-C20-03	95B066750	NAMUR	65
IS-08-C20-S1	95B066790	NAMUR	65
IS-08-C20-S2	95B066770	NAMUR	65
IS-08-C2-03	95B061551	BASIC	15
IS-08-C2-S1	95B061571	BASIC	15
IS-08-C2-S2	95B061561	BASIC	15
IS-08-C3-03	95B066410	BASIC	15
IS-08-C3-S1	95B061481	BASIC	15
IS-08-C3-S2	95B061471	BASIC	15
IS-08-C4-03	95B066450	BASIC	15

IS-08-C4-S1	95B061511	BASIC	15
IS-08-C4-S2	95B061501	BASIC	15
IS-08-D1-03	95B062321	BASIC	17
IS-08-D1-S1	95B066970	BASIC	17
IS-08-D1-S2	95B066700	BASIC	17
IS-08-D2-03	95B062351	BASIC	17
IS-08-D2-S1	95B067000	BASIC	17
IS-08-D2-S2	95B066720	BASIC	17
IS-08-D3-03	95B066430	BASIC	17
IS-08-D3-S1	95B066920	BASIC	17
IS-08-D3-S2	95B066650	BASIC	17
IS-08-D4-03	95B062291	BASIC	17
IS-08-D4-S1	95B066940	BASIC	17
IS-08-D4-S2	95B066670	BASIC	17
IS-08-G1-03	95B066370	BASIC	18
IS-08-G1-S1	95B066850	BASIC	18
IS-08-G1-S2	95B066580	BASIC	18
IS-08-G2-03	95B066390	BASIC	18
IS-08-G2-S1	95B066880	BASIC	18
IS-08-G2-S2	95B066610	BASIC	18
IS-08-G3-03	95B066330	BASIC	18
IS-08-G3-S1	95B066800	BASIC	18
IS-08-G3-S2	95B066520	BASIC	18
IS-08-G4-03	95B066350	BASIC	18
IS-08-G4-S1	95B063131	BASIC	18
IS-08-G4-S2	95B066550	BASIC	18
IS-08-H1-03	95B066480	BASIC	19
IS-08-H1-S1	95B066960	BASIC	19
IS-08-H1-S2	95B066690	BASIC	19
IS-08-H2-03	95B066500	BASIC	19
IS-08-H2-S1	95B066990	BASIC	19
IS-08-H2-S2	95B063301	BASIC	19
IS-08-H3-03	95B066420	BASIC	19
IS-08-H3-S1	95B066910	BASIC	19
IS-08-H3-S2	95B066640	BASIC	19
IS-08-H4-03	95B066460	BASIC	19
IS-08-H4-S1	95B063251	BASIC	19
IS-08-H4-S2	95B063241	BASIC	19
IS-08-M1-03	95B066380	STAINLESS STEEL	38
IS-08-M1-S1	95B066870	STAINLESS STEEL	38
IS-08-M1-S2	95B066600	STAINLESS STEEL	38
IS-08-M2-03	95B066400	STAINLESS STEEL	38
IS-08-M2-S1	95B066900	STAINLESS STEEL	38
IS-08-M2-S2	95B066630	STAINLESS STEEL	38
IS-08-M3-03	95B066340	STAINLESS STEEL	38
IS-08-M3-S1	95B066820	STAINLESS STEEL	38
IS-08-M3-S2	95B066540	STAINLESS STEEL	38
IS-08-M4-03	95B066360	STAINLESS STEEL	38
IS-08-M4-S1	95B066840	STAINLESS STEEL	38
IS-08-M4-S2	95B066570	STAINLESS STEEL	38
IS-08-N1-03	95B066490	STAINLESS STEEL	39
IS-08-N1-S1	95B066980	STAINLESS STEEL	39
IS-08-N1-S2	95B066710	STAINLESS STEEL	39
IS-08-N2-03	95B066510	STAINLESS STEEL	39
IS-08-N2-S1	95B067010	STAINLESS STEEL	39
IS-08-N2-S2	95B066730	STAINLESS STEEL	39
IS-08-N3-03	95B066440	STAINLESS STEEL	39
IS-08-N3-S1	95B066930	STAINLESS STEEL	39
IS-08-N3-S2	95B066660	STAINLESS STEEL	39
IS-08-N4-03	95B066470	STAINLESS STEEL	39
IS-08-N4-S1	95B066950	STAINLESS STEEL	39
IS-08-N4-S2	95B066680	STAINLESS STEEL	39

M12			
SENSOR	Order No.	Category	Pag.
IS-12-A0-03	95B064030	BASIC	20
IS-12-A0-S2	95B064060	BASIC	20
IS-12-A1-03	95B061241	BASIC	20
IS-12-A1-S2	95B061251	BASIC	20
IS-12-A15-03	95B060680	INDUCTIVE AC	56
IS-12-A15-S2	95B060690	INDUCTIVE AC	56
IS-12-A20-03	95B064160	NAMUR	66
IS-12-A20-S2	95B064180	NAMUR	66
IS-12-A2-03	95B061271	BASIC	20
IS-12-A2-S2	95B061281	BASIC	20
IS-12-A3-03	95B061181	BASIC	20
IS-12-A3-S2	95B061191	BASIC	20
IS-12-A4-03	95B061211	BASIC	20
IS-12-A4-S2	95B061221	BASIC	20
IS-12-A9-03	95B064100	BASIC	20
IS-12-A9-S2	95B063931	BASIC	20
IS-12-B0-03	95B064040	BASIC	21
IS-12-B1-03	95B062041	BASIC	21
IS-12-B1-S2	95B062051	BASIC	21
IS-12-B2-03	95B062071	BASIC	21
IS-12-B2-S2	95B062081	BASIC	21
IS-12-B3-03	95B061981	BASIC	21
IS-12-B3-S2	95B061991	BASIC	21
IS-12-B4-03	95B062011	BASIC	21
IS-12-B4-S2	95B062021	BASIC	21
IS-12-C0-S2	95B064080	BASIC	20
IS-12-C1-03	95B061641	BASIC	20
IS-12-C1-S2	95B061651	BASIC	20
IS-12-C20-03	95B064170	NAMUR	66
IS-12-C20-S2	95B064190	NAMUR	66
IS-12-C2-03	95B061671	BASIC	20
IS-12-C2-S2	95B061681	BASIC	20
IS-12-C3-03	95B061581	BASIC	20
IS-12-C3-S2	95B061591	BASIC	20
IS-12-C4-03	95B061611	BASIC	20
IS-12-C4-S2	95B061621	BASIC	20
IS-12-C9-03	95B064110	BASIC	20
IS-12-C9-S2	95B064140	BASIC	20
IS-12-D1-03	95B062441	BASIC	21
IS-12-D1-S2	95B062451	BASIC	21
IS-12-D2-03	95B062471	BASIC	21
IS-12-D2-S2	95B062481	BASIC	21
IS-12-D3-03	95B062381	BASIC	21
IS-12-D3-S2	95B062391	BASIC	21
IS-12-D4-03	95B062411	BASIC	21
IS-12-D4-S2	95B062421	BASIC	21
IS-12-E1-S2	95B067030	BASIC	22
IS-12-F1-S2	95B067020	BASIC	22
IS-12-G0-03	95B063841	BASIC	23
IS-12-G0-S2	95B064070	BASIC	23
IS-12-G1-03	95B063361	BASIC	23
IS-12-G1-S2	95B063371	BASIC	23
IS-12-G2-03	95B063381	BASIC	23
IS-12-G2-S2	95B063391	BASIC	23
IS-12-G3-03	95B063321	BASIC	23
IS-12-G3-S2	95B063331	BASIC	23
IS-12-G4-03	95B063341	BASIC	23
IS-12-G4-S2	95B063351	BASIC	23
IS-12-G5-03	95B062681	BASIC	23
IS-12-G5-S2	95B062691	BASIC	23
IS-12-G6-03	95B062661	BASIC	23
IS-12-G6-S2	95B062671	BASIC	23

# CABLES, CONNECTORS & ACCESSORIES

IS-12-G9-03	95B063801	BASIC	23
IS-12-G9-S2	95B064130	BASIC	23
IS-12-H0-03	95B064050	BASIC	23
IS-12-H0-S2	95B064090	BASIC	23
IS-12-H1-03	95B063441	BASIC	23
IS-12-H1-S2	95B063451	BASIC	23
IS-12-H2-03	95B063461	BASIC	23
IS-12-H2-S2	95B063471	BASIC	23
IS-12-H3-03	95B063401	BASIC	23
IS-12-H3-S2	95B063411	BASIC	23
IS-12-H4-03	95B063421	BASIC	23
IS-12-H4-S2	95B063431	BASIC	23
IS-12-H5-03	95B062761	BASIC	23
IS-12-H5-S2	95B062771	BASIC	23
IS-12-H6-03	95B062741	BASIC	23
IS-12-H6-S2	95B062751	BASIC	23
IS-12-H9-03	95B064120	BASIC	23
IS-12-H9-S2	95B064150	BASIC	23
IS-12-I1-S2	95B065340	METAL FACE	48
IS-12-L1-S2	95B063871	METAL FACE	48
IS-12-M1-S2	95B060240	STAINLESS STEEL	40
IS-12-M2-S2	95B060250	STAINLESS STEEL	40
IS-12-M3-S2	95B060260	STAINLESS STEEL	40
IS-12-M4-S2	95B060270	STAINLESS STEEL	40
IS-12-N1-S2	95B060280	STAINLESS STEEL	40
IS-12-N2-S2	95B060290	STAINLESS STEEL	40
IS-12-N3-S2	95B060300	STAINLESS STEEL	40
IS-12-N4-S2	95B060310	STAINLESS STEEL	40
IS-12-O1-S2	95B060000	STAINLESS STEEL	41
IS-12-O2-S2	95B060010	STAINLESS STEEL	41
IS-12-O3-S2	95B060020	STAINLESS STEEL	41
IS-12-O4-S2	95B060030	STAINLESS STEEL	41
IS-12-P1-S2	95B060040	STAINLESS STEEL	41
IS-12-P2-S2	95B060050	STAINLESS STEEL	41
IS-12-P3-S2	95B060060	STAINLESS STEEL	41
IS-12-P4-S2	95B060070	STAINLESS STEEL	41
IS-12-P4-S2	95B060070	STAINLESS STEEL	41
IS-F12-S1-S2	95B065360	WELD FIELD IMMUNE	52
IS-F12-T1-S2	95B065370	WELD FIELD IMMUNE	52

IS-18-B4-03	95B062121	BASIC	25
IS-18-B4-S2	95B062131	BASIC	25
IS-18-C0-03	95B064240	BASIC	24
IS-18-C0-S2	95B064280	BASIC	24
IS-18-C1-03	95B061741	BASIC	24
IS-18-C1-S2	95B061751	BASIC	24
IS-18-C20-03	95B064370	NAMUR	67
IS-18-C20-S2	95B064390	NAMUR	67
IS-18-C2-03	95B061761	BASIC	24
IS-18-C2-S2	95B061771	BASIC	24
IS-18-C3-03	95B061701	BASIC	24
IS-18-C3-S2	95B061711	BASIC	24
IS-18-C4-03	95B061721	BASIC	24
IS-18-C4-S2	95B061731	BASIC	24
IS-18-C9-03	95B064310	BASIC	24
IS-18-C9-S2	95B064340	BASIC	24
IS-18-D1-03	95B062541	BASIC	25
IS-18-D1-S2	95B062551	BASIC	25
IS-18-D2-03	95B062561	BASIC	25
IS-18-D2-S2	95B062571	BASIC	25
IS-18-D3-03	95B062501	BASIC	25
IS-18-D3-S2	95B062511	BASIC	25
IS-18-D4-03	95B062521	BASIC	25
IS-18-D4-S2	95B062531	BASIC	25
IS-18-E1-S2	95B067050	BASIC	26
IS-18-F1-S2	95B067040	BASIC	26
IS-18-G0-03	95B063851	BASIC	27
IS-18-G0-S2	95B064270	BASIC	27
IS-18-G1-03	95B063521	BASIC	27
IS-18-G1-S2	95B063531	BASIC	27
IS-18-G2-03	95B063541	BASIC	27
IS-18-G2-S2	95B063551	BASIC	27
IS-18-G3-03	95B063061	BASIC	27
IS-18-G3-S2	95B063491	BASIC	27
IS-18-G4-03	95B063501	BASIC	27
IS-18-G4-S2	95B063511	BASIC	27
IS-18-G5-03	95B062721	BASIC	27
IS-18-G5-S2	95B062731	BASIC	27
IS-18-G6-03	95B064200	BASIC	27
IS-18-G6-S2	95B062711	BASIC	27
IS-18-G9-03	95B063811	BASIC	27
IS-18-G9-S2	95B064330	BASIC	27
IS-18-H0-03	95B064250	BASIC	27
IS-18-H0-S2	95B064290	BASIC	27
IS-18-H1-03	95B063601	BASIC	27
IS-18-H1-S2	95B063611	BASIC	27
IS-18-H2-03	95B063621	BASIC	27
IS-18-H2-S2	95B063631	BASIC	27
IS-18-H3-03	95B063561	BASIC	27
IS-18-H3-S2	95B063571	BASIC	27
IS-18-H4-03	95B063581	BASIC	27
IS-18-H4-S2	95B063591	BASIC	27
IS-18-H5-03	95B064220	BASIC	27
IS-18-H5-S2	95B062811	BASIC	27
IS-18-H6-03	95B064210	BASIC	27
IS-18-H6-S2	95B062791	BASIC	27
IS-18-H9-03	95B064320	BASIC	27
IS-18-H9-S2	95B064350	BASIC	27
IS-18-I1-S2	95B065350	METAL FACE	49
IS-18-L1-S2	95B063881	METAL FACE	49
IS-18-M1-S2	95B060320	STAINLESS STEEL	42
IS-18-M2-S2	95B060330	STAINLESS STEEL	42
IS-18-M3-S2	95B060340	STAINLESS STEEL	42
IS-18-M4-S2	95B060350	STAINLESS STEEL	42

## M18

SENSOR	Order No.	Category	Pag.
IS-18-A0-03	95B064230	BASIC	24
IS-18-A0-S2	95B064260	BASIC	24
IS-18-A1-03	95B061341	BASIC	24
IS-18-A1-S2	95B061351	BASIC	24
IS-18-A15-03	95B060770	INDUCTIVE AC	57
IS-18-A15-S2	95B060780	INDUCTIVE AC	57
IS-18-A20-03	95B064360	NAMUR	67
IS-18-A20-S2	95B064380	NAMUR	67
IS-18-A2-03	95B061361	BASIC	24
IS-18-A2-S2	95B061371	BASIC	24
IS-18-A3-03	95B061301	BASIC	24
IS-18-A3-S2	95B061311	BASIC	24
IS-18-A4-03	95B061321	BASIC	24
IS-18-A4-S2	95B061331	BASIC	24
IS-18-A9-03	95B064300	BASIC	24
IS-18-A9-S2	95B063941	BASIC	24
IS-18-B1-03	95B062141	BASIC	25
IS-18-B1-S2	95B062151	BASIC	25
IS-18-B2-03	95B062161	BASIC	25
IS-18-B2-S2	95B062171	BASIC	25
IS-18-B3-03	95B062101	BASIC	25
IS-18-B3-S2	95B062111	BASIC	25

IS-18-N1-S2	95B060360	STAINLESS STEEL	42
IS-18-N2-S2	95B060370	STAINLESS STEEL	42
IS-18-N3-S2	95B060380	STAINLESS STEEL	42
IS-18-N4-S2	95B060390	STAINLESS STEEL	42
IS-18-O1-S2	95B060080	STAINLESS STEEL	43
IS-18-O2-S2	95B060090	STAINLESS STEEL	43
IS-18-O3-S2	95B060100	STAINLESS STEEL	43
IS-18-O4-S2	95B060110	STAINLESS STEEL	43
IS-18-P1-S2	95B060120	STAINLESS STEEL	43
IS-18-P2-S2	95B060130	STAINLESS STEEL	43
IS-18-P3-S2	95B060140	STAINLESS STEEL	43
IS-18-P4-S2	95B060150	STAINLESS STEEL	43
IS-F18-S1-S2	95B065380	WELD FIELD IMMUNE	53
IS-F18-T1-S2	95B065390	WELD FIELD IMMUNE	53

M30

SENSOR	Order No.	Category	Pag.
IS-30-A0-03	95B064460	BASIC	28
IS-30-A0-S2	95B064490	BASIC	28
IS-30-A1-03	95B061421	BASIC	28
IS-30-A1-S2	95B061431	BASIC	28
IS-30-A15-03	95B060810	INDUCTIVE AC	58
IS-30-A15-S2	95B060820	INDUCTIVE AC	58
IS-30-A20-03	95B064610	NAMUR	68
IS-30-A20-S2	95B064630	NAMUR	68
IS-30-A2-03	95B061441	BASIC	28
IS-30-A2-S2	95B061451	BASIC	28
IS-30-A3-03	95B061381	BASIC	28
IS-30-A3-S2	95B061391	BASIC	28
IS-30-A4-03	95B061401	BASIC	28
IS-30-A4-S2	95B061411	BASIC	28
IS-30-A9-03	95B064530	BASIC	28
IS-30-A9-S2	95B064570	BASIC	28
IS-30-B1-03	95B062221	BASIC	29
IS-30-B1-S2	95B062231	BASIC	29
IS-30-B2-03	95B062241	BASIC	29
IS-30-B2-S2	95B062251	BASIC	29
IS-30-B3-03	95B062181	BASIC	29
IS-30-B3-S2	95B062191	BASIC	29
IS-30-B4-03	95B062201	BASIC	29
IS-30-B4-S2	95B062211	BASIC	29
IS-30-C0-03	95B064470	BASIC	28
IS-30-C0-S2	95B064510	BASIC	28
IS-30-C1-03	95B061821	BASIC	28
IS-30-C1-S2	95B061831	BASIC	28
IS-30-C20-03	95B064620	NAMUR	68
IS-30-C20-S2	95B064640	NAMUR	68
IS-30-C2-03	95B061841	BASIC	28
IS-30-C2-S2	95B061851	BASIC	28
IS-30-C3-03	95B061781	BASIC	28
IS-30-C3-S2	95B061791	BASIC	28
IS-30-C4-03	95B061801	BASIC	28
IS-30-C4-S2	95B061811	BASIC	28
IS-30-C9-03	95B064550	BASIC	28
IS-30-C9-S2	95B064590	BASIC	28
IS-30-D1-03	95B062621	BASIC	29
IS-30-D1-S2	95B062631	BASIC	29
IS-30-D2-03	95B062641	BASIC	29
IS-30-D2-S2	95B062651	BASIC	29
IS-30-D3-03	95B062581	BASIC	29
IS-30-D3-S2	95B062591	BASIC	29
IS-30-D4-03	95B062601	BASIC	29
IS-30-D4-S2	95B062611	BASIC	29
IS-30-E1-S2	95B067060	BASIC	31

IS-30-G0-03	95B063861	BASIC	30
IS-30-G0-S2	95B064500	BASIC	30
IS-30-G1-03	95B063681	BASIC	30
IS-30-G1-S2	95B063691	BASIC	30
IS-30-G2-03	95B063701	BASIC	30
IS-30-G2-S2	95B063711	BASIC	30
IS-30-G3-03	95B063641	BASIC	30
IS-30-G3-S2	95B063651	BASIC	30
IS-30-G4-03	95B063661	BASIC	30
IS-30-G4-S2	95B063671	BASIC	30
IS-30-G5-03	95B063821	BASIC	30
IS-30-G5-S2	95B063831	BASIC	30
IS-30-G6-03	95B064400	BASIC	30
IS-30-G6-S2	95B064430	BASIC	30
IS-30-G9-03	95B064540	BASIC	30
IS-30-G9-S2	95B064580	BASIC	30
IS-30-H0-03	95B064480	BASIC	30
IS-30-H0-S2	95B064520	BASIC	30
IS-30-H1-03	95B063761	BASIC	30
IS-30-H1-S2	95B063771	BASIC	30
IS-30-H2-03	95B063781	BASIC	30
IS-30-H2-S2	95B063791	BASIC	30
IS-30-H3-03	95B063721	BASIC	30
IS-30-H3-S2	95B063731	BASIC	30
IS-30-H4-03	95B063741	BASIC	30
IS-30-H4-S2	95B063751	BASIC	30
IS-30-H5-03	95B064420	BASIC	30
IS-30-H5-S2	95B064450	BASIC	30
IS-30-H6-03	95B064410	BASIC	30
IS-30-H6-S2	95B064440	BASIC	30
IS-30-H9-03	95B064560	BASIC	30
IS-30-H9-S2	95B064600	BASIC	30
IS-30-M1-S2	95B060400	STAINLESS STEEL	44
IS-30-M2-S2	95B060410	STAINLESS STEEL	44
IS-30-M3-S2	95B060420	STAINLESS STEEL	44
IS-30-M4-S2	95B060430	STAINLESS STEEL	44
IS-30-N1-S2	95B060440	STAINLESS STEEL	44
IS-30-N2-S2	95B060450	STAINLESS STEEL	44
IS-30-N3-S2	95B060460	STAINLESS STEEL	44
IS-30-N4-S2	95B060470	STAINLESS STEEL	44
IS-30-O1-S2	95B060160	STAINLESS STEEL	45
IS-30-O2-S2	95B060170	STAINLESS STEEL	45
IS-30-O3-S2	95B060180	STAINLESS STEEL	45
IS-30-O4-S2	95B060190	STAINLESS STEEL	45
IS-30-P1-S2	95B060200	STAINLESS STEEL	45
IS-30-P2-S2	95B060210	STAINLESS STEEL	45
IS-30-P3-S2	95B060220	STAINLESS STEEL	45
IS-30-P4-S2	95B060230	STAINLESS STEEL	45

SQUARE

SENSOR	Order No.	Category	Pag.
IS-40-C11-S3	95B065330	SQUARE	74
IS-40-W5-S3	95B065240	SQUARE	72
IS-40-W6-S3	95B065230	SQUARE	72
IS-40-W7-S3	95B065250	SQUARE	73
IS-40-W8-S3	95B065260	SQUARE	73
IS-40-X5-S2	95B065320	SQUARE	74
IS-40-X6-S2	95B065310	SQUARE	74
IS-40-Y5-S3	95B065280	SQUARE	72
IS-40-Y6-S3	95B065270	SQUARE	72
IS-40-Y7-S3	95B065290	SQUARE	73
IS-40-Y8-S3	95B065300	SQUARE	73
IS-88-Q1-03	95B060830	SQUARE	75
IS-88-Q1-S1	95B060840	SQUARE	75

























2025-2026 *Journal of the American Veterinary Medical Association* |  | [www.avma.org](http://www.avma.org)

## HEADQUARTERS

### Datalogic Automation Srl

Via Lavino, 265  
40050 Monte San Pietro - Bologna - Italy  
Tel. +39 051/6765611  
Fax +39 051/6759324  
info.automation.it@datalogic.com

## BRANCHES AND SALES OFFICES

## EUROPE

### BENELUX

#### Datalogic Automation Benelux

Newtonweg 3  
4104 BK Culemborg  
The Netherlands  
Tel. +31 345/589489  
Fax +31 345/511419  
info.automation.nl@datalogic.com

### FRANCE

#### Datalogic Automation Srl

Succursale en France  
Le Parc Technologique de Lyon  
333 cours du 3ème Millénaire - Le Pôle  
69800 Saint Priest  
Tél. +33 (0)4/72476180  
Fax +33 (0)4/72470721  
info.automation.fr@datalogic.com

### GERMANY

#### Datalogic Automation Srl

Niederlassung Central Europe  
Carl-Zeiss Str. 31  
73230 Kirchheim/Teck  
Tel. +49 (0)7021/509700  
Fax +49 (0)7021/5097029  
info.automation.de@datalogic.com

### ITALY

#### Datalogic Automation Srl

Via Lavino, 265  
40050 Monte San Pietro - Bologna  
Tel. +39 051/6765611  
Fax +39 051/6759324  
info.automation.it@datalogic.com

### Datalogic Automation Srl

#### LASER MARKING

Via Le Gorrey, 10  
11020, Donnas - Aosta  
Tel. +39-0125-8128201  
Fax +39-0125-8128401  
info.automation.it@datalogic.com

Via Dell'Industria 20, 21018  
Sesto Calende - Varese  
Tel. +39-03319180601  
Fax +39-03319180801  
info.automation.it@datalogic.com

### SPAIN

#### Datalogic Automation Iberia

Sucursal en España  
C/Samontà, 21 Planta baja, Local 0  
08970 Sant Joan Despí - Barcelona  
Tel. +34 (0)93/4772059  
Fax +34 (0)93/477272  
info.automation.es@datalogic.com

### NORDIC

#### Datalogic Automation AB

Höjdrodergatan 21  
21239 Malmö - Sweden  
Tel. +46 (0)40/385000  
Fax +46 (0)40/385001  
info.automation.se@datalogic.com

### UNITED KINGDOM

#### Datalogic Automation UK

Datalogic House  
Dunstable Road, Redbourn - Hertfordshire  
AL3 7PR  
Tel. +44 (0) 1582 791750  
Fax +44 (0) 1582 791769  
info.automation.uk@datalogic.com

## NORTH AMERICA

### Datalogic Automation Inc

511 School House Road  
Telford, PA 18969-1196 - United States  
Tel. +1-800-BAR-CODE or +1-215-723-0981  
Fax +1-215-721-5551  
info.automation.us@datalogic.com

### Datalogic Automation Inc

#### MACHINE VISION

5775 W Old Shakopee Rd  
STE 160, Bloomington, MN 55437  
United States  
Tel. +1-952-996-9500  
Fax +1-952-996-9501  
info.automation.us@datalogic.com

## APAC

## AUSTRALIA-NEW ZEALAND

### Datalogic Automation Pty Ltd

Unit 130, 45 Gilby Road  
Mt Waverley - Victoria, 3149 - Australia  
Tel. +61 (0)3/95589299  
Fax: +61 (0)3/95589233  
info.automation.au@datalogic.com

## CHINA

### Datalogic Automation Asia

Floor 20, Room 2017, Building 2,  
16 West Nan San Huan Road  
Fengtai District, Beijing  
Tel: +86 (0)21-5836 6692  
Fax: +86 (0)21-5836 6695  
info.automation.cn@datalogic.com

Suite 1301, Hua Rong Plaza,  
1289 South Pudong Road, Pudong District  
Shanghai 200120  
Tel: +86 (0)21-5836 6692  
Fax: +86 (0)21-5836 6695  
info.automation.cn@datalogic.com

Room 1104B, 5#Tower, Fantasta MIC Plaza,  
West Nanhai Road, Nanshan District,  
518054 Shenzhen, Guangdong, China  
Tel: +86 (0)755-8629 6779  
Fax: +86 (0)755-8628 1280  
info.automation.cn@datalogic.com

## JAPAN

### Idec Datalogic Co. Ltd

10-40, Mikuni-Honmachi 1-Chome,  
Yodogawa-ku, Osaka 532 0005  
Tel. +81(6) 6398/3200  
Fax +81 (6) 6398/3202  
www.idljp.com



Rev. 03, 11/2013



9C513700E

Product and Company names and logos referenced may be either trademarks or registered trademarks of their respective companies. We reserve the right to make modifications and improvements.



# DATALOGIC

www.datalogic.com