

REFERENCE GUIDE



> Laser Marking



DATALOGIC
THE VISION IS YOURS

DATALOGIC: SOLUTIONS FOR INDUSTRIAL AUTOMATION

Datalogic Industrial Automation is an industry-leader in products and solutions for material handling, traceability, inspection and detection applications.

With the acquisitions of Accu-Sort and PPT Vision in 2012, the company offers a comprehensive portfolio of products, technologies and solutions delivered by a team of skilled professionals dedicated to providing superior service to customers.

Datalogic is the partner of choice for organizations in the Industrial Automation market.

Manufacturing

- AUTOMOTIVE
- ELECTRONICS
- FOOD & BEVERAGE
- GENERAL MANUFACTURING
- HEALTHCARE - PHARMACEUTICAL

Transportation & Logistics

- AIRPORTS
- COURIER, EXPRESS PARCEL (CEP)
- POSTAL
- RETAIL DISTRIBUTION

Product portfolio

Datalogic Industrial Automation has the most comprehensive offering of products and solutions for traceability, inspection and detection applications in factory automation and logistics processes: industrial laser scanners, cameras and vision systems, sensors, machine safety devices and laser markers.

Identification

Even the most demanding and efficient automation identification processes can leverage Datalogic Industrial Automation's leadership in the market. We manufacture the world's most comprehensive family of fixed-mount line and omnidirectional scanners.

We also offer the latest CCD vision technology with the world's largest installed base of CCD systems for bar code reading and dimensioning.

All of our AUTO-ID products and solutions leverage the broadest decoding library that has been developed through the years. Datalogic's comprehensive AUTO-ID portfolio is used in a wide range of applications and machines which are behind many of the everyday processes that keeps the global economy running.

Sensors & Safety

Datalogic Industrial Automation offers a best-in-class, comprehensive product portfolio of photoelectric and proximity sensors, rotary encoders, temperature controllers and measurement devices, as well as type 2 and type 4 safety light curtains.

These product lines provide solutions for applications involving color, contrast and luminescence, label detection, dimensional and distance measurement, in addition to machine safeguarding and access control in dangerous areas.

Machine Vision

The Datalogic Industrial Automation machine vision product line encompasses both hardware and software while covering a wide range of performance and price point requirements. The vision portfolio of products and solutions ranges from simple vision sensors to smart cameras and embedded vision systems.

Laser Marking

Laser Marking sources and systems provide value driven marking solutions for automotive, metal tools, medical, electronics and packaging. Datalogic Industrial Automation offers an extensive range of state-of-the-art technology, excellent performance and high reliability marking equipment.



Datalogic Laser Marking overview	6
What is laser marking? How does it work?	8
Advantages of laser marking	9
Laser marking processes	10
Laser marking technologies	16
Laser applications	20
Automotive	20
Electronics	22
Food	24
Pharmaceutical	26
Lighter software	28
Laser marking products	36
Accessories	44



DATALOGIC LASER MARKING OVERVIEW

Datalogic Laser Marking is able to provide the best laser technology solution for your application, from fiber laser to solid state and CO₂, powered by the laser technology.

With the increasing popularity of Fiber lasers in recent years, Datalogic invested aggressively in this technology, and now we can offer a complete range of laser marking solutions that meets the requirements for speed, quality and budget.

Datalogic's product portfolio provides users the ability to select the perfect technology to provide the best results through a single software platform with a single interface.

No other manufacturer is so vertically integrated on Fiber technology (Pulsed and MOPA), Solid State technology (IR, GREEN & UV) software and hardware.

TECHNOLOGIES

FIBER LASER

High reliability fiber laser technology

TIMELINE

1993

Laservall SPA was founded

1994

Laservall is the leader of jewelry laser welding

1995

VIOLINO First industrial grade DPSS laser marker

1996

Medical, Aesthetical, Dental laser sources were introduced

1997

KUBO is the new family of stand alone spot welders

2000

New Production plant in Sesto Calende. Large class 1000 clean rooms

2002

Laservall Asia was founded

2003

Laservall Korea was founded

2003

Eurmarker low cost laser marker

TECHNOLOGY

latest software platform and hardware controller.

of proprietary fiber laser sources. Moreover, when selecting a laser marker it is important to choose the best technology for the application and material

flexible controller and integration I/O options.

controllers, scanning heads and marking system design!



D.P.S.S.
DIODE PUMPED
High peak power,
multi-wavelength
solid state technology

CO₂
Consolidated technology
for painted, coated or
organic material

2004	2006	2007	2008	2011	2012	2013	2013	2014	2015	2016
Datalogic acquires Laservall SPA	XELL was introduced	Datalogic provides 550 laser systems for Spanish DNI (Documento Nacional de Identidad)	ULYXE first ultra compact all-in-one laser marker introduced	EOX, CO ₂ laser marker introduced	AREX fiber laser based marking system introduced	Datalogic introduces FILOS fiber laser source based on proprietary technology	Datalogic acquires high power pulsed fiber laser assets and technology of Multiwave Photonics S.A.	Datalogic offers the most complete range of laser marking products and sources	UniQ™ fiber laser marker introduced	Datalogic introduces AREX 20MW, M.O.P.A. fiber laser maker.



WHAT IS LASER MARKING? HOW DOES IT WORK?

Laser marking is a way to permanently mark a physical item for branding, tracking, coding, personalizing, either for security or quality control reasons.

During the process, an intense, collimated laser light beam is focused on the surface of a target. By scanning this concentrated spot with moving mirrors on the target's surface the laser beam can create image.

Depending on laser source characteristics, an instantaneous peak power density of several hundred kilowatts are delivered on the target causing instantaneous modification to the surface.

Laser Marking does not involve the use of inks, masks, solvents, acids, nor does it require tools which contact the engraving surface and wear over time. These properties distinguish laser engraving from alternative engraving or marking technologies where inks or bit heads have to be replaced regularly.

While most forms of engraving result in a loss of some of the marked material when it is etched away, laser marking results in essentially no loss of material. Instead, the laser is used to create a shift in the color of the material, creating a visible, virtually indestructible mark with minimal impact to the item.

Laser marking's environmental impact is low, since the technology does not utilize inks, solvents, or other consumables. Environmentally-conscious companies realize both the cost savings and environmental friendliness to laser marking solutions.

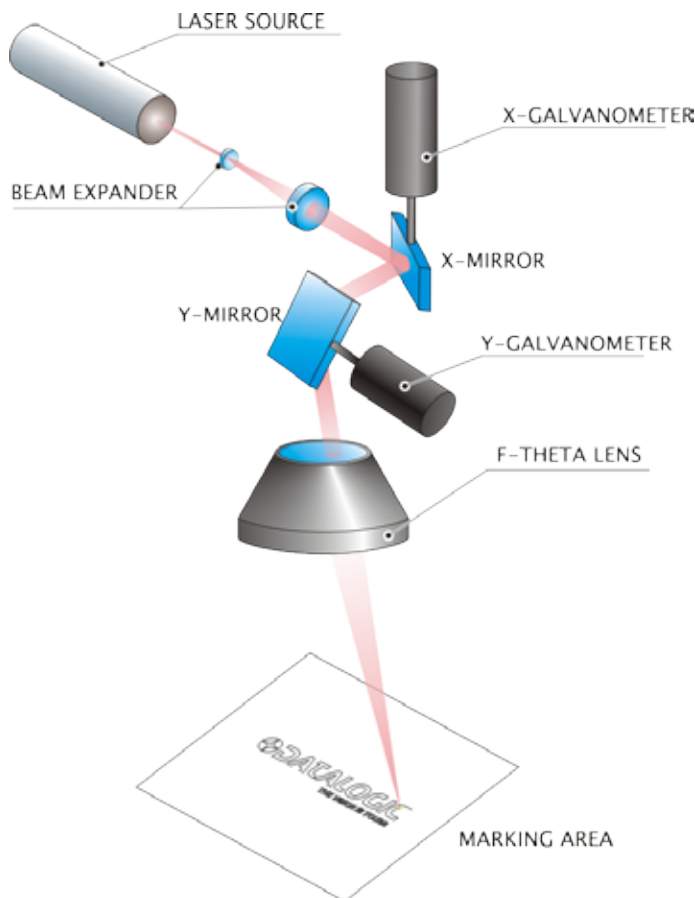

Laser marking is obtained by delivering and focusing a laser beam on a target surface with motorized mirrors controlled by dedicated hardware and software. Synchronizing the XY movement with the power modulation of the laser beam a non-contact and permanent mark is applied to the target surface.

ADVANTAGES OF LASER MARKING

Laser marking technology is the preferred choice in manufacturing due to its intrinsic advantages:

- **PERMANENT & DURABLE**
Abrasion proof, water, solvent, oil, temperature, UV resistant marking
- **COUNTERFEIT PROOF**
Strong interaction with substrate: Tamper proof, impossible to alter or remove
- **LONG TERM CONTRAST & READABILITY**
Human and machine readable over long periods of time
- **NON CONTACT, CLEAN & DRY**
Solvent and ink free with no mechanical interactions with materials, complex clamping or special handling systems, with no drying time
- **FAST - HIGH PRODUCTIVITY**
On-the-fly and static marking with up to 1000 characters per second
- **HIGH RESOLUTION, HIGH QUALITY**
High resolution for graphics, logos or fonts, up to 600 DPI
- **FLEXIBLE**
Fixed, variable, or dynamic text, full vectorial and bitmap graphics, 1D & 2D bar codes
- **RELIABLE & ENVIRONMENTALLY FRIENDLY**
No paint, ink, acid, solvents or chemicals with no waste or downtime. Excellent energy efficiency.



LASER MARKING PROCESSES

1 - ANNEALING

Materials:

Ferrous metals (iron, steel)
Titanium

Laser marking product:

AREX Series- Fiber Laser Marker
VLASE Series – DPSS Laser Marker
UNIQT[™] - Fiber Laser Marker

Laser annealing is a marking technique that uses laser irradiation to thermally induce local oxidation without noticeable material ablation, this process creates an indelible, permanent black mark without any cracks, depressions or burrs suitable for already finished surfaces like high surface precision on surgical instruments and tools.

Typical annealing processes usually penetrate 20 to 30 μm deep in the metal surface, resulting in a stable marking that is corrosion-proof ensuring the mark cannot be removed by acid, solvents, or abrasive techniques.

This dark, permanent mark is perfect for medical device applications where marks withstand passivation, salt spray testing, and autoclaving and where material removal is prohibited to ensure part integrity and surface quality.

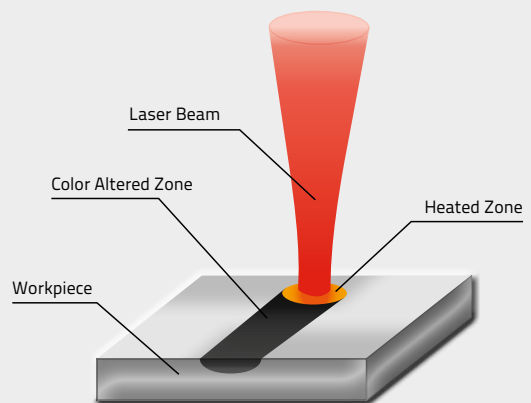

2 - ENGRAVING

Materials:

Metals
Thermoplastic
Paper, wood, organics

Laser marking products:

AREX Series- Fiber Laser Marker
VLASE Series – DPSS Laser Marker
EOX Series – CO₂ Laser Marker
UNIQT[™] - Fiber Laser Marker

In laser engraving, the laser beam locally overheats the workpiece material to the vaporization point. In some cases, thermal effects are very evident with large Heat Affected Zones (HAZ), colored oxides can be produced at the bottom or the engraving further accentuating the marking.

A depression is created in the workpiece through melting displacement and/or vaporization of material. Typical engraving depths vary between 0,001mm to 0,1mm and almost any material can be engraved with a suitable laser source (Fiber, YAG, CO₂). Deep engraving is a method to create durable, direct and forgery-proof product marking which is resistance to wear and corrosion, even after painting or coating processes as used in automotive applications.

Deep engraving also includes 3D marking, which is the progressive removal of several layers of material at different depths to create a three-dimensional carving into the workpiece. 3D marking relies on external devices to reposition the focus field to affect different layers along the Z axis. Typical deep engraving depths vary between 0,1mm to 5mm.

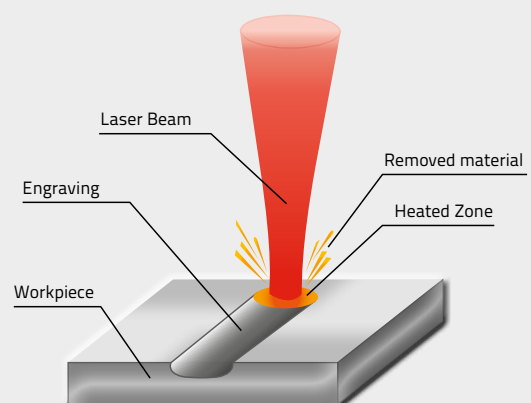

3 - SURFACE ETCHING

Material marked:

Metals

Laser marking product:

AREX series – Fiber Laser Marker

VLASE series – DPSS Laser Marker

ULYXE – Compact DPSS Laser Marker

UNIQT[™] – Fiber Laser Marker

The laser etching process consists of using laser irradiation to alter the superficial finish of a metal and create contrast by enhancing the way it reflects ambient light.

Depth of penetration usually does not exceed 0.01mm. Laser etching is probably the most widely used high speed laser marking process.

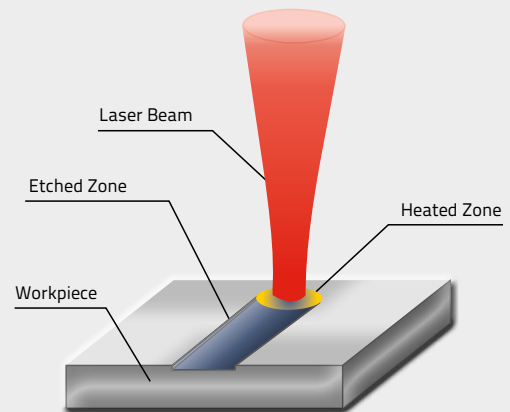

4 - COATING ABLATION / PAINT STRIPPING

Materials:

ANY, depending on coating

Laser marking product:

AREX Series- Fiber Laser Marker

VLASE Series – DPSS Laser Marker

EOX Series – CO₂ Laser Marker

UNIQT[™] – Fiber Laser Marker

Ablation marking process consists of the partial/complete removal of one or more coating layers which exposes the contrasting color of the substrate material.

This process is popular for backlight marking and 'night & day' buttons and keys in the automotive, computer and mobile electronics industries, where a dark spray coating is applied on a transparent substrate, and then selectively ablated by laser irradiation. Short pulses with high peak reduces the thermal impact on the material resulting in high resolution marking. Laser ablation can also be used to prepare substrates for other steps in the production process. For example welding of oily, dirty or oxidized surface or when an electrical contact is needed on metal frames. In these applications, cleaning and chemical agents can be eliminated and replaced with laser ablation.

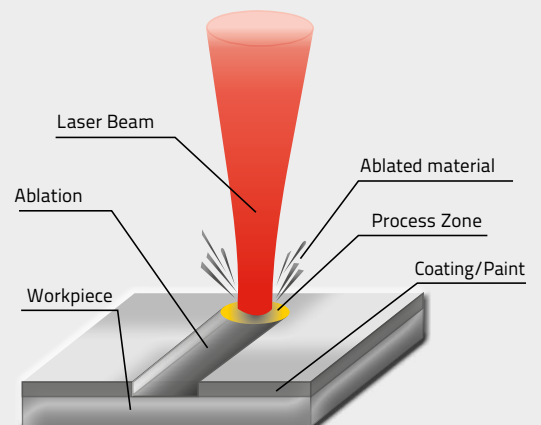

LASER MARKING PROCESSES

5 - FOAMING

Materials:

Thermoplastic Materials

Laser marking product:

AREX Series- Fiber Laser Marker

VLASE Series – DPSS Laser Marker

UNIQT[™] - Fiber Laser Marker

Due to laser absorption and low thermal conductivity the local workpiece temperature rises to its melting point. Small gas bubbles appear in the molten material, which increases its volume creating a type of plastic foam. The processed area appears much brighter than the surrounding material. This process is typically enhanced using laser marking additives that increase contrast and the reliability of the marking process. The foaming marking process is usually tactile and with poor scratch resistance.

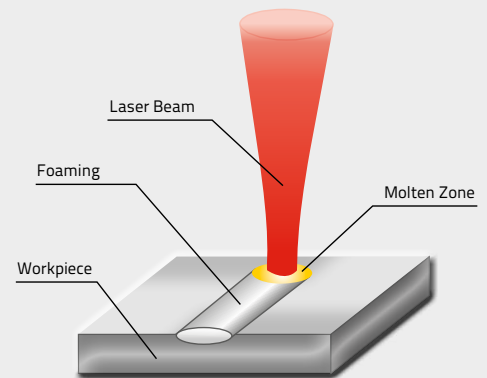

6 - COLOR CHANGE / BLACKENING / BLEACHING

Materials:

Thermoplastic Materials

Laser marking product:

AREX Series- Fiber Laser Marker

VLASE Series – DPSS Laser Marker

UNIQT[™] - Fiber Laser Marker

On some thermoplastic materials 'green lasers' (second harmonic lasers @ 532 nm) and 'UV lasers' (third harmonic lasers @ 355 nm) can be used for bleaching and photo reduction marking processes.

This effect is also called 'cold marking' for the reduced 'thermal footprint' on the substrate.

great benefits in terms of contrast, speed and stability of the marking process, can be The use of laser-sensitive additives in plastics can generate considerable advantages.

Additives in plastics are able to increase outline sharpness and contrast and thus boost readability of the marking contents e.g. of machine-readable codes. Used with transparent and semi-transparent materials, additives lead to a uniform contrast dispersal. Additives in plastics increase the diversity of product colors and are of crucial importance for the markability of certain materials.

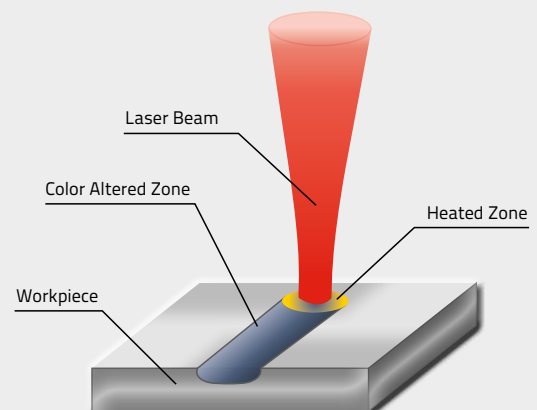

7 - CARBONIZATION/ENGRAVING WITH CARBONIZATION

Materials:

Thermoplastic Materials
Paper, Wood, Organics

Laser marking product:

AREX Series- Fiber Laser Marker
VLASE Series – DPSS Laser Marker
EOX – Series – CO₂ Laser

Carbonization of one or more specific pigments, flame retardants or other additives will provide consistent marking with sharp contrast in most light colored thermoplastic materials. Engraving may be present depending on the vaporization of the material and its absorption level.

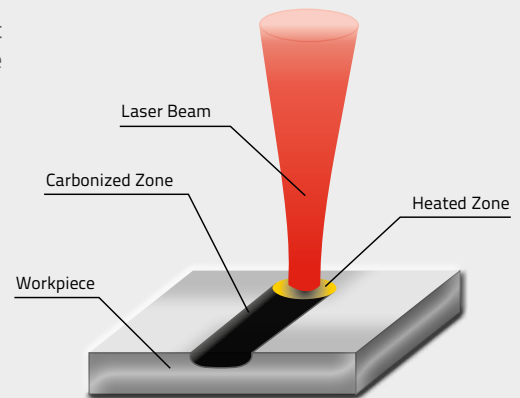

8 - SUBSURFACE LASER ENGRAVING (SSLE)

Materials:

Glass, transparent materials

Laser marking product:

VLASE Series – DPSS Laser Marker

Focusing intense laser radiation below the surface of a glass object creates a mark made of micro-cracks induced by localized absorption of the laser light. As a result, microscopic cracks cause multiple internal light reflections which makes the spot look white. Without affecting the polished surfaces, two and three dimensional images can be created inside of the glass. The images are created dot by dot and the workpiece is moved in two or three dimensions. This technique is popular for decoration as well as tamper-proof traceability.

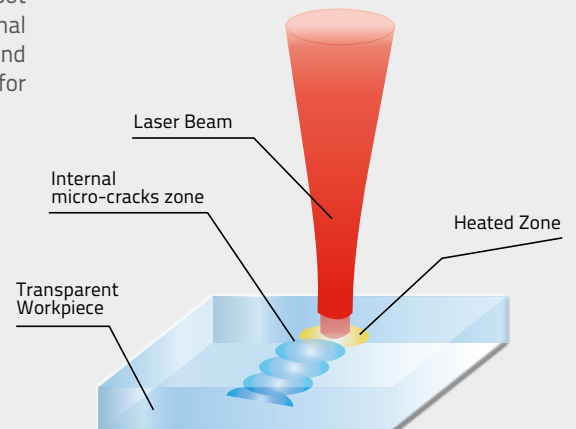

LASER MARKING PROCESSES

9 - COLOR MARKING ON FERROUS METALS AND TITANIUM

Materials:

Ferrous metals (iron, steel)
Titanium

Laser marking product:

AREX 20 MW – MOPA Fiber Laser Marker

Laser Color Marking of stainless steel and titanium is a well-known marking technique but still with a limited diffusion in the industry.

Like laser annealing, laser color marking is based on surface oxidation, varying different laser parameters will result in different oxide coatings that can be seen as different colors by the viewer.

Most important parameters in laser marking are the focal spot diameter, power on sample, marking speed, line spacing, marking direction, repetition rate and pulse length.

Thanks to the capability to control laser pulse-width, and to its high stability, MOPA fiber lasers enable homogeneous and reliable color marking on ferrous metals and titanium.

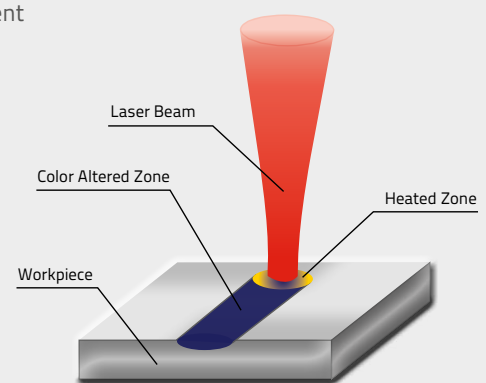

10 - BLACK MARKING ON ANODIZED ALUMINUM

Materials:

Anodized aluminum

Laser marking product:

AREX 20 MW – MOPA Fiber Laser Marker

The so called 'black marking' is a technique widely used by mobile device manufacturers to mark logos and serial numbers on the anodized aluminum case with high contrast, pleasing appearance and feel and no damage on the protective oxide layer.

Thanks to the capability to run at short pulses, to the high level of control of energy and peak power, Mopa fiber lasers are the best choice to combine real black appearance with the benefits of laser marking without corrupting the corrosion properties of the coated material.

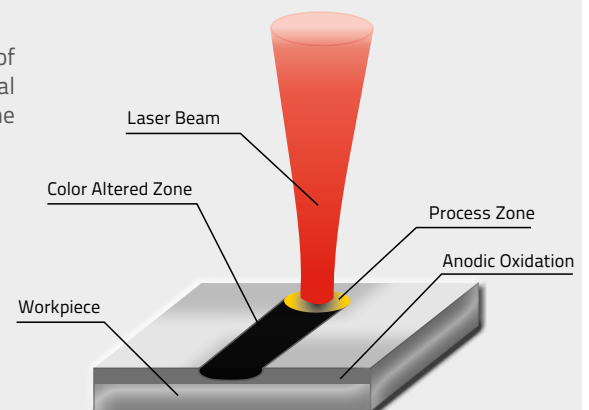

LASER MARKING TECHNOLOGIES



LASER MARKING TECHNOLOGIES

FIBER LASER

Fiber lasers are not new in Industrial Laser Marking, CW fiber sources have been used for high speed marking of integrated circuits (IC) since 1998. In recent years, fiber lasers have tremendously progressed in terms of flexibility and overall performance enabling the 'Fiber Revolution' in the laser market.

With a monolithic, solid state, fiber-to-fiber design which eliminates mirrors and optics to align or adjust, fiber lasers have technological advantages that dramatically improve reliability and repeatability of laser processes.

Fiber lasers also offer integration and operational advantages:

- Fiber lasers are compact and deliver their energy through an flexible optical fiber
- Fiber lasers are scalable and more efficient than any other laser technology, with wall-plug efficiencies greater than 30%
- Fiber lasers offer higher and stable beam quality and excellent pulse-to-pulse stability ensuring the best repeatability over time, especially for critical marking processes
- Q-Switched Fiber lasers offer a long pulse-width (typ 100 nsec) that make these sources the first choice for marking metal in the automotive industry
- MULTIWAVE M.O.P.A. fiber laser technology offers the capability to select the emission pulsewidth from 4 ns to 250 ns ensuring superb marking performances in term of process optimization and repeatability.

APPLICATIONS & MATERIALS



High contrast marking on metal



Metals: engraving & deep engraving on metal



Color change on thermoplastic polymer with additive

SOLID STATE LASER

Diode Pumped Solid State Lasers (DPSSL) represent the most consolidated technology for laser marking applications and are still the most flexible solution to generate green and UV laser radiation.

The capability to provide extremely high peak power (up to 10 times higher than standard Fiber Lasers) and short pulse duration, make these laser sources very aggressive for difficult-to-mark materials such as highly reflective metals (copper, brass, silver, gold,...) or very stable polymer plastic.

Solid state lasers emission @ 1064 nm can be efficiently converted into GREEN emission @532 nm (SHG Second Harmonic Generation) and UV emission @355nm (THG Third Harmonic Generation) enabling the capability to engrave virtually any kind of material with extremely high resolution and reduced Heat Affected Zones (HAZ). DPSSL are ideal for even thermally sensitive materials like silicon wafers, WLCSP, thin memory cards, ICs or highly reflective materials (copper, gold, silver).

DPSS lasers are suitable to process, damage free marking process high tech, multilayers, sensitive materials and components in Aerospace, and high technology Industry.

- DPSS lasers offer highest Peak Power and Short pulse width, providing cold process, extremely aggressive marking spot, even on stable and hard to engrave materials.
- DPSS lasers are easy to repair.
- DPSS lasers are available even with GREEN and UV emission, for low thermal footprint marking process.
- DPSS lasers are the first choice for Thermoplastic Polymer Marking in electronics / electromechanical Industry.

APPLICATIONS & MATERIALS

INFRARED



Color change on high stability plastic polymer



Paint stripping, coating removal



Night & day



Paint stripping



Surface modification



High contrast marking on highly reflective metal



UV glass marking

LASER MARKING TECHNOLOGIES

CO₂ LASER

Developed over 50 years ago, the CO₂ laser has captured the largest portion of the laser materials processing market. Current day CO₂ lasers are the best solutions for high thermal impact marking with wavelengths 10x longer than DPSS and Fiber lasers. The long wavelength (10600 nm) is extremely efficient on typical packaging materials, such as:

- Paper, Corrugated Cardboard
- Glass, Ceramic
- Plastic polymer, Rubber
- Painted, coated material (metals, plastic PCB)

APPLICATIONS & MATERIALS



PCB marking



Packaging materials - heat sensitive coatings and cardboard

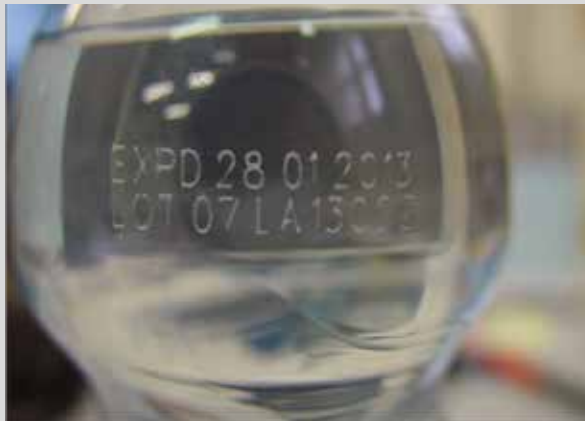

High speed PET coding



Direct marking on cardboard

LASER APPLICATIONS



AUTOMOTIVE

PARTS TRACEABILITY & DPM

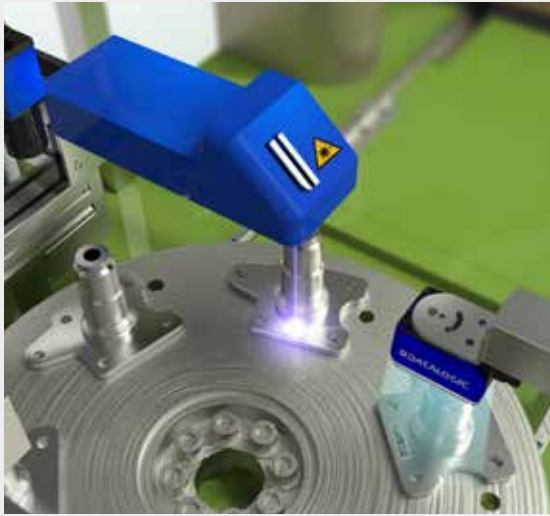

Direct Part Marking (DPM) of parts and components during assembly process

BENEFITS

- Direct part marking: no ink, no label
- Highly configurable serial numbering features including time/date, shift coding etc.
- Comprehensive 1D and 2D bar code library with advanced cell filling functions
- Built-in scripting capability for custom data formatting and integration with external database
- Deep engraving for end-of-life traceability
- Contactless operation : no mechanical stress or deformation on target



INSPECTION



Quality verification of parts during the manufacturing process

BENEFITS

- Higher, consistent and non-subjective product quality
- Early inspection prevents processing defective material and allows for the identification of bad parts that can be reworked
- Contactless inspection: no deformation of the inspected part
- Wide range of solutions: from low to very high resolution inspection
- IMPACT software delivers maximum inspection flexibility: part gauging, surface verification, assembling control, component positioning

COMPONENTS MARKING



Parts are branded and personalized with manufacturer logos, graphics or quality marks.

BENEFITS

- Extreme flexibility: automatically change data on every mark, including logo, date, lot, order codes etc.
- Full range of options for drawing, importing and editing logos and graphics
- Comprehensive Windows® True Type font library including Unicode language support.
- Low-maintenance and cost-efficient
- Small and compact scanhead footprint for easy integration into existing production lines
- Minimal integration and setup time
- Built-in I/O for easy integration into automated production lines



ELECTRONICS

LASER CUTTING

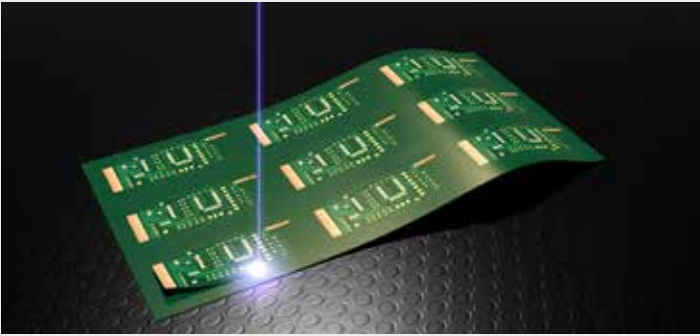

Stress free PCB cutting, drilling and depaneling for flex-rigid circuitry. Suitable for ITO/TCO processing and for cutting ceramic based materials

BENEFITS

- Low thermal footprint, no mechanical stress
- Rated for 24/7 operation
- Cost effective solution
- Broad range of materials



DPM READING AND CODE QUALITY VERIFICATION

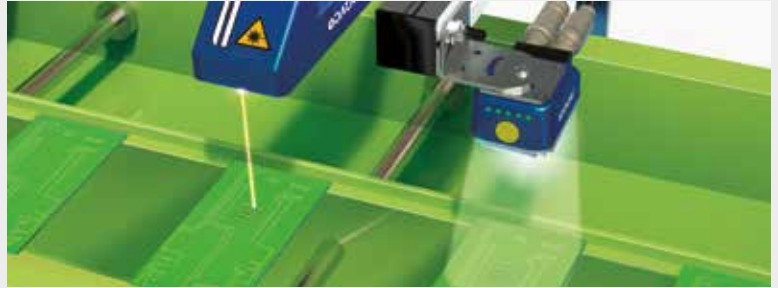

Tracking of a PCB is made easy through Direct Part Marking (DPM). 2D code validation after a laser marking station assures the correct information and 2D code readability.

BENEFITS

- YAG laser marking protection for mark-and-read solutions
- High density code reading on very small codes
- Code quality analysis for statistical process trending



LASER TRIMMING

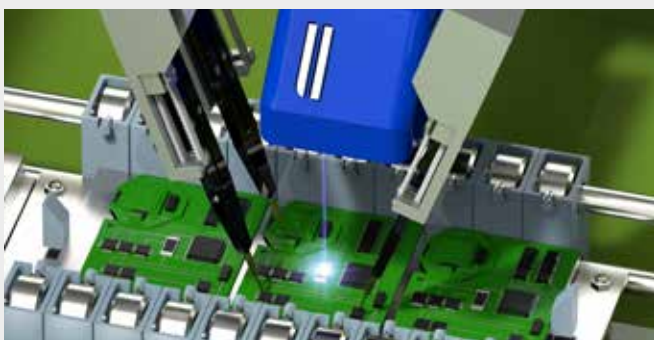

Active laser trimming of electronic circuits and SMD components and other SMD components

BENEFITS

- Low thermal footprint, reduced kerf width
- Accurate and precise beam positioning
- High speed ablation
- Easy integration and reduced setup time

WAFER MARKING

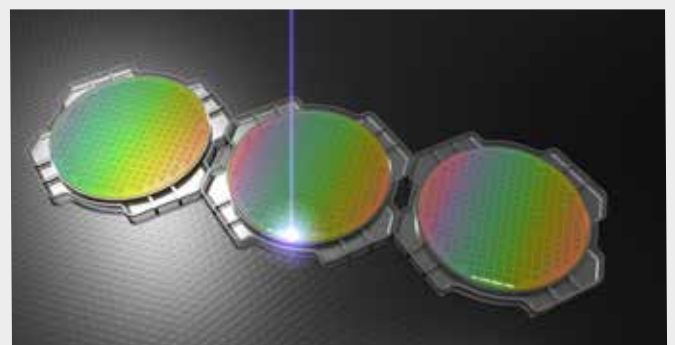

Stress & debris-free marking, by melting the silicon

BENEFITS

- Low thermal footprint, no mechanical stress
- Rated for 24/7 operation
- Cost effective solution
- Machine-readable marks

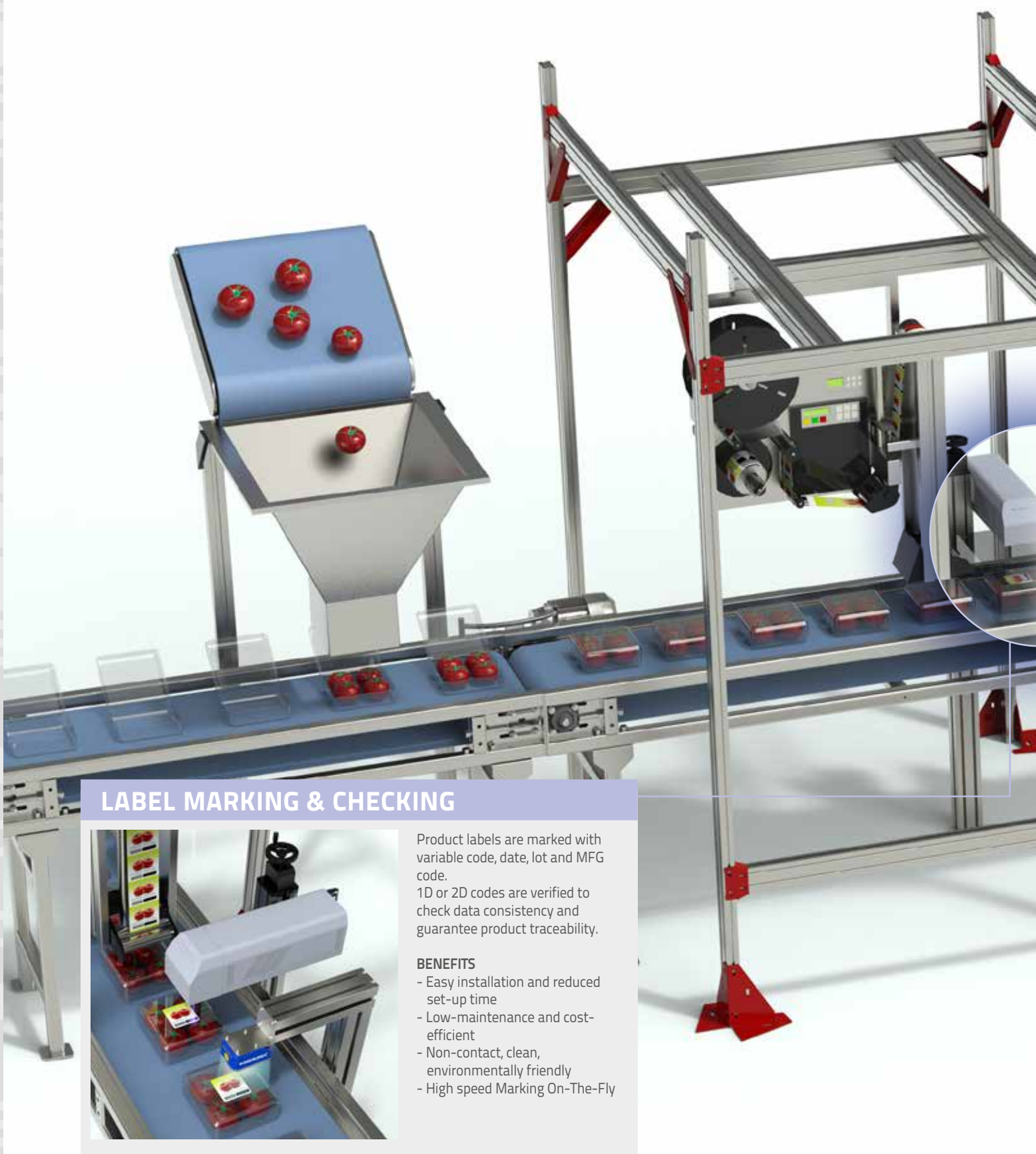

LABEL MARKING & CHECKING

Product labels are marked with variable code, date, lot and MFG code. 1D or 2D codes are verified to check data consistency and guarantee product traceability.

BENEFITS

- Easy installation and reduced set-up time
- Low-maintenance and cost-efficient
- Non-contact, clean, environmentally friendly
- High speed Marking On-The-Fly



"EXPIRATION" DATE CODING



Laser markers remove the dark layer of a pre-printed label to create a permanent high contrast, high quality code. 'Best Before' date, lot, manufacturing plant code and other information can be added after the labeling process.

BENEFITS

- Clean alternative to inkjet: no ink, solvent to refill, no drying time
- Environmentally friendly
- Very high quality, contrast and resolution
- Highly configurable serial numbering features including time/date, shift coding etc.
- Comprehensive 1D and 2D bar code library with advanced cell filling functions
- Built-in scripting capability for custom data formatting and integration with external database
- High speed, marking-on-the-fly
- Low total cost of ownership, reduced maintenance

PHARMACEUTICAL

CAP INSPECTION

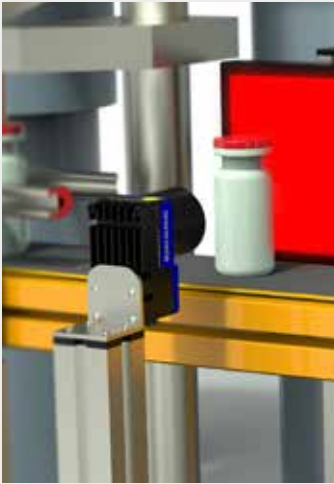

The pharmaceutical industry requires high performance solutions for product inspection, coding and tracking.

This inspection ensures the product quality by verifying the bottle cap is present and applied correctly. Normally, this inspection is performed at high rates of speed prior to the sealing and final packaging process where visual inspection is not possible without reopening the sealed package.

BENEFITS

- High speed, high accuracy quality control
- Full product traceability
- Certified product integrity
- Image and data archiving for quality reporting



MARK, READ & INSPECT

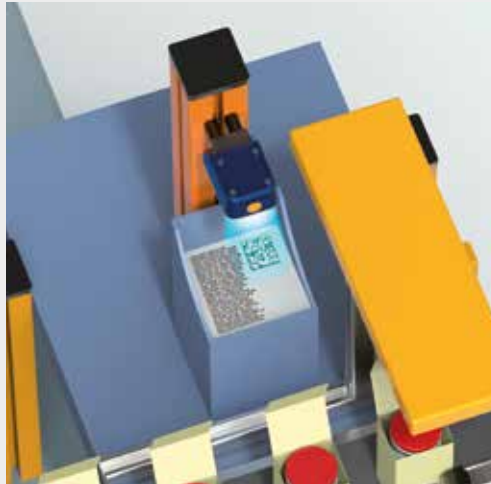

Complete integrated track, trace and control solutions with laser marking, inspection and bar code reading to guarantee accurate and efficient processes.

BENEFITS

- Correct match of drug, package and drug facts leaflet
- Full track&trace system
- Total traceability of every product component



LASER CODING AND VERIFICATION



LASER CODING

Critical variable product information is permanently marked directly or on laser activated labels. The combination of human readable data and 2D codes identifies the product, the manufacturer, the batch number and the expiration date.

CODE VERIFICATION

Checking for critical variable product information on labels to verify data consistency and maintain quality standards.

BENEFITS

- Complete label inspection: 1D/2D code and OCR reading
- Total control of product serialization
- Information readability verification



LIGHTER SOFTWARE



LIGHTER SOFTWARE

LIGHTER: the unique **Software Suite** for all Datalogic Laser Marking Products. Thanks to its innovative software design and features, **LIGHTER** represents an important step-ahead on the market, setting a new standard in term of ease of use and ease integration.

Thanks to its full graphical interface, **LIGHTER** joins advanced editing features with laser setup, controls and diagnostic for complete, flexible and ease of use laser marking system control.

LIGHTER SUITE is based on a quick-to-learn powerful WYSIWYG (What You See Is What You Get) graphical LASER EDITOR and an easy-to-use, LASER ENGINE. This two-GUIs approach guarantee effective results in term of flexibility and operating speed.



LASER EDITOR: Advanced Editing Function

- Full Graphical interface, to easily design and edit any kind of marking layout.
- Built-in Property Browser for fast setting of all parameters
- Creates and edits texts, codes, imported vectorial graphics, logo, etc.
- Comprehensive and powerful coding library for 1D and 2D code (100+ code styles available)
- Direct import and edit of bitmap and vectors logo and graphics (BMP, PNG, GIF, JPG, SVG, TIF, PLT, DXF, DWG, AI, ...)
- Advanced filling and hatching features for objects and pattern structures with various styles.
- True Type Font (TTF) import tool, with advanced editing features (rounded text, slanted, compression etc.)
- Unicode language support
- Mark Preview – exact view of marking vectors.
- Clone function , array capabilities for IC marking,
- Gray tones marking

ADVANCED HATCHING FEATURES AND CAPABILITIES

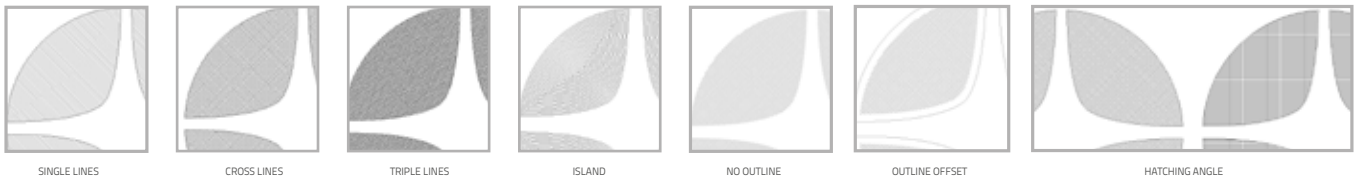

ABCDEFGHIJKLMNOPQRSTUVWXYZ - 1234567890
 ABCDEFGJKLMNPOQRSTUVWXYZ - 1234567890
 ABCDEFGJKLMNPOQRSTUVWXYZ - 1234567890

Script - Abodeghijklmnopqrstuvwxyz - 1234567890

احصائيات الموقع 搜索开放源代码
 한국어/조G말 अन्नेज़ी से हिन्दी



Text Text Text

Text Text

Text Text



Embedded coding library supports linear, 2D, GS1 and composite symbologies. QR-Code, Datamatrix, are supported as well as other 100+ code styles.

Automation Capability

LIGHTER SUITE incorporates additional features to simplify automation and integration with automatic lines.

- Embedded Stepper Motor controller: up to 4 axes independent Mechanical Axis(X, Y, Z and Rotary/indexer) at layout level
- User configurable general purpose I/Os with built-in I/Os monitor
- Marking-on-Fly (MOF) capabilities with Setup Wizard for easy set-up
- Sequence Editor to easily create sequential automated in a few clicks
- Powerful built-in counters and Global Variables Manager for serializing applications
- Built-in Material database
- Built in Script Engine for interaction with local or centralized database

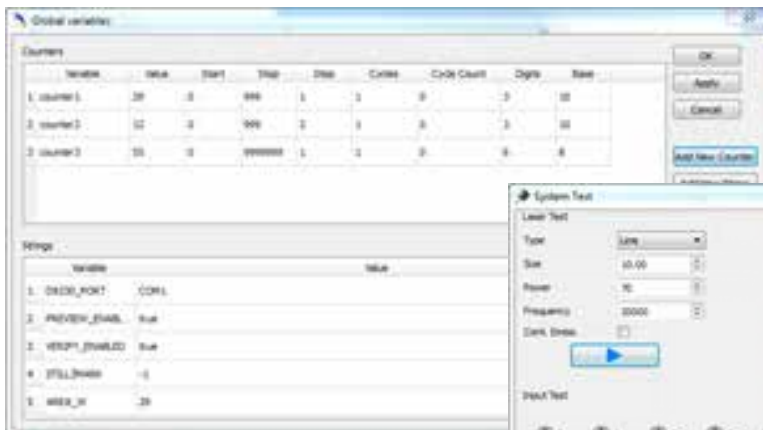

GLOBAL VARIABLES MANAGER

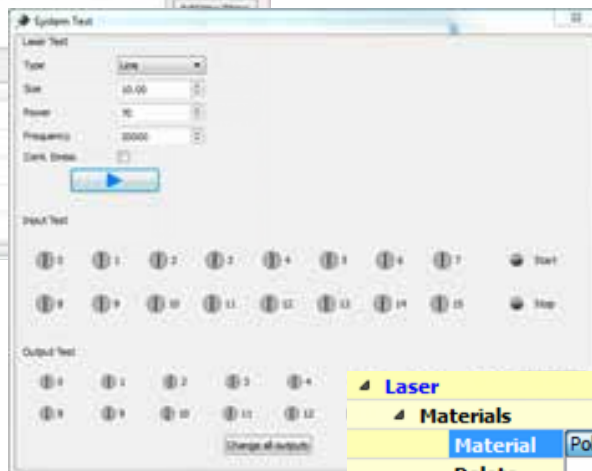

LASER TEST & I/O MONITOR

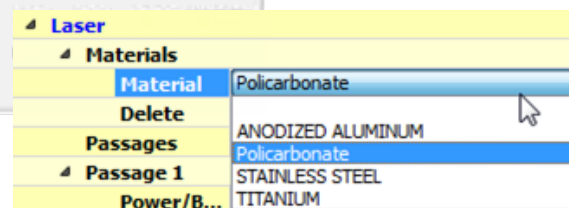

MATERIAL DATABASE

CONFIGURATION FLEXIBILITY

LIGHTER SUITE allows OEMs and Machine builders to develop a complete, cost effective, Laser Marking Station, based on embedded hardware and software resources, (STAND ALONE mode) or to design an advanced Laser Marking Solutions able to control a complete machinery over a simple Ethernet connection with supervisor computer (MASTER-SLAVE mode).

Full control, both in local and remote mode via Laser Editor GUI:

- Local/Remote laser configuration, included MOF Wizard, laser diagnostic, I/O test
- Local/Remote I/O & axis control
- Local/Remote Automation Project control
- Local/Remote Active X support

EXAMPLE OF CONFIGURATION:

PRODUCTION MODE – UNATTENDED

Master Slave configuration is dedicated to remotely control one or more Laser Marking product over a simple Ethernet connection with a supervisor computer.

- Laser system can be installed without monitor or keyboard,
- Laser system is programmed from remote supervisor computer connected via LAN and work completely unattended.
-
- MASTER-SLAVE configuration is also useful in case of complex graphics editing or in case of interaction with other
- Vectorial Graphic Software (CorelDraw, Autocad, etc.) installed on a graphical workstation.

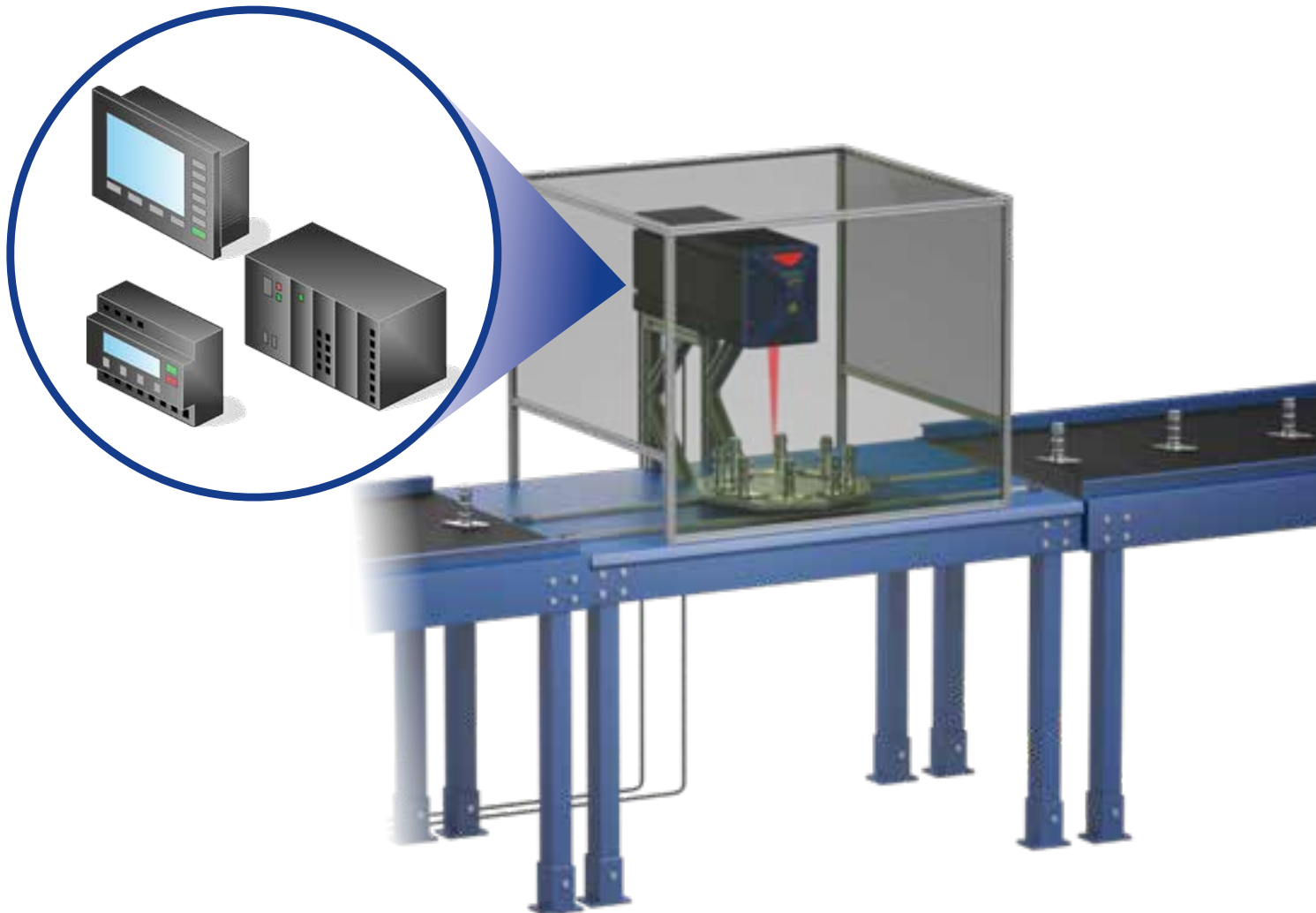

PRODUCTION MODE – UNATTENDED

PRODUCTION MODE is dedicated to repetitive production batches, where a simplified interface with limited editing capability is required.

Lighter Laser Engine provide only one easy GUI interface for laser control, marking task selection, AUTO/MANUAL marking mode, and full diagnostic.

Scripting Programmability allow integrators and End Users to create customized GUI and automated procedures to update layouts contents at runtime.



JOB-SHOP - INTERACTIVE

JOB SHOP – INTERACTIVE MODE is dedicated to small batches productions with the highest flexibility.

- Just one software interface for design, editing and laser control, including setup and configuration, allows laser users to quickly & friendly create, import, modify and engrave text, logos, codes bitmap etc.
- Manual and Automatic modes, axis control, laser test and laser configuration are easily accessible from Lighter Editor main screen as well as system status and diagnostic.

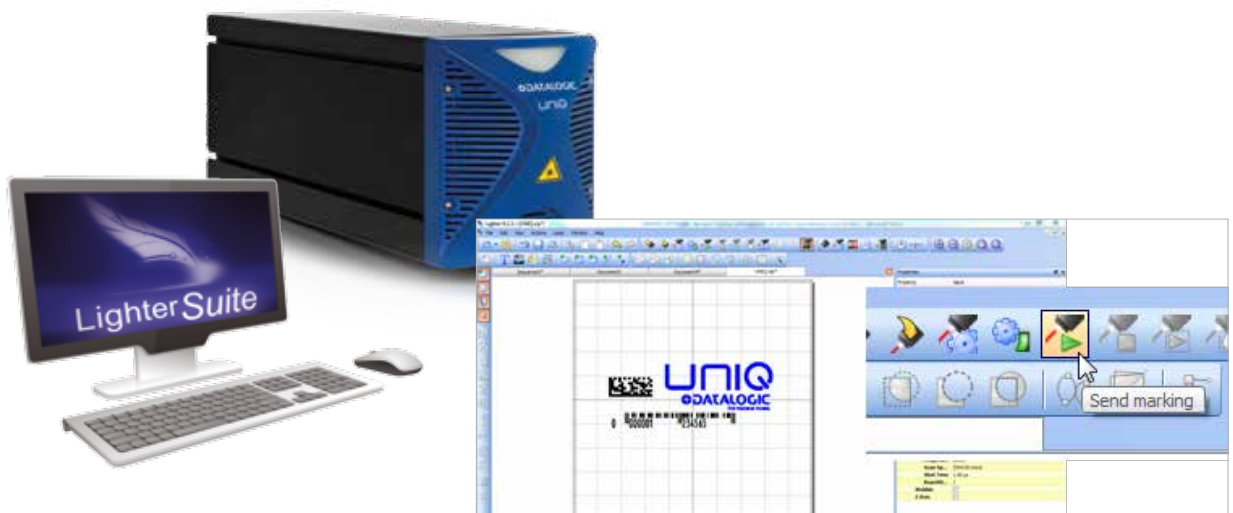

LIGHTER SOFTWARE

PROGRAMMABLE INTERFACES AND PERSONALIZATION CAPABILITIES

LIGHTER is scriptable this means that it can be easily integrated with legacy systems through a wide range of combinations of transmission media, protocols and architectures

LIGHTER 6 Suite integrates the IDE (Integrated Development Environment) providing to the users a full set of tools to be used for extremely flexible customization; The programming language is ECMAScript standard (also called JavaScript). With Project Editor it is possible:

- control the marking process with customized user's interface
- automatically create, modify, update and customize layouts at runtime
- create dedicated and custom GUI for efficient user interaction
- interact with other DLA's devices (Vision Sensors, Vision Systems, industrial ID reader)

Customized Laser Engine operative interface are easy and affective to automatize production process.

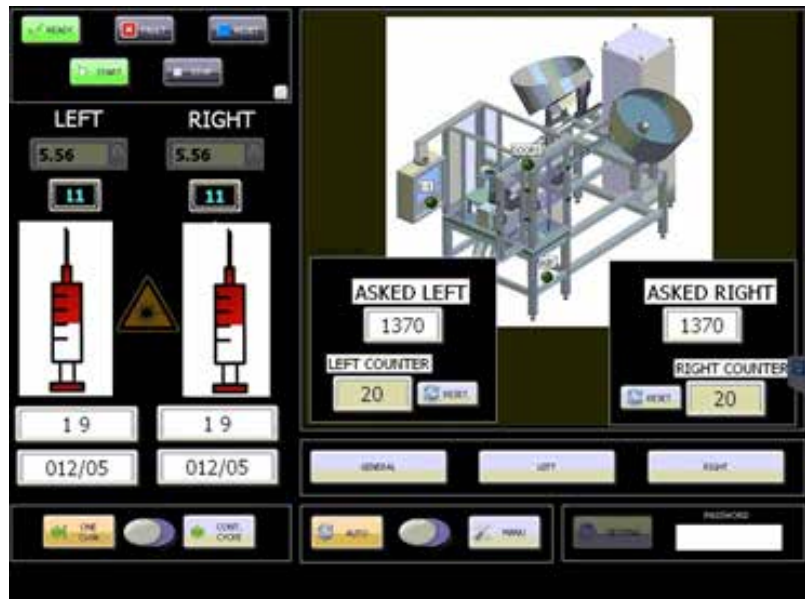
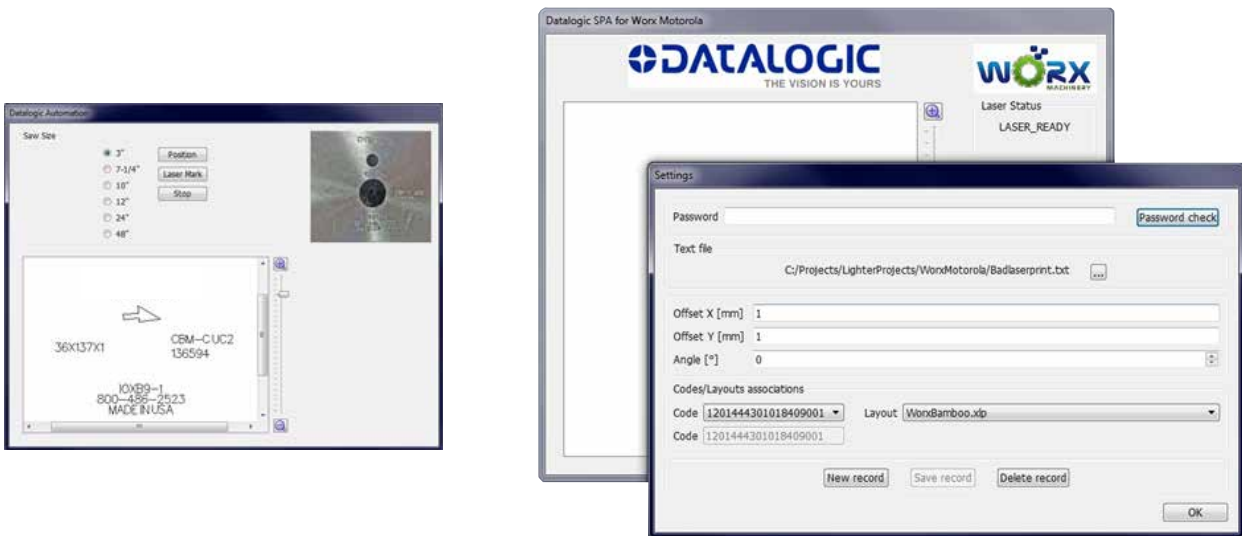

IP ActiveX allows OEM integrators and end-users to create customized Applications and User Interfaces via Ethernet.

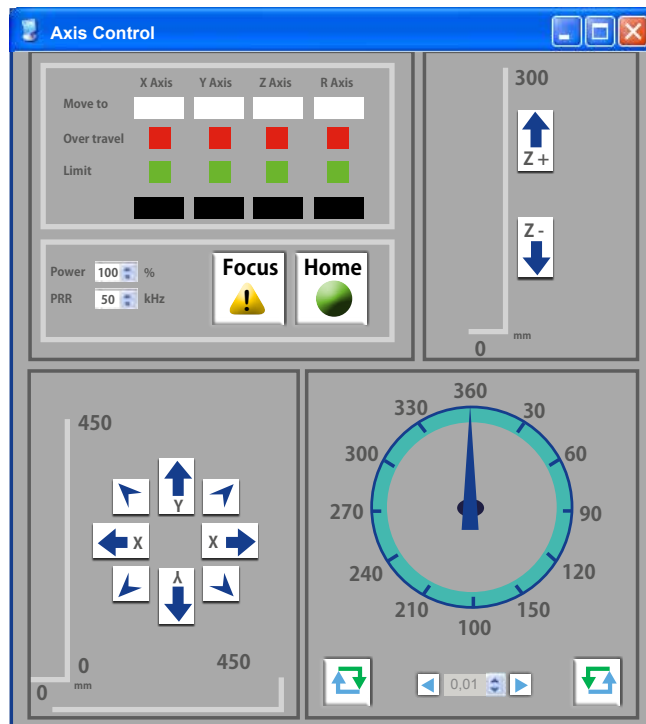

TECHNICAL FEATURES

User Interface	Languages	English, Italian, German, Spanish, French, Polish, Japanese, Traditional Chinese, Simplified Chinese, Korean.
	OS supported	Windows 10, Windows 8, Windows 7, Windows XP.
	Access	Password protected user levels
Character type	Font	Original single line, True Type, Open Type, Type1, Type42
	Languages	Unicode language support
European, Asian and all 'non-latin' languages Arabic, Cyrillic and Hindi	Text	Fixed text, linear and radial text, customizable date/time objects, serial number, batch code, fully customizable code
Code type	Barcode	2to5, Code39, Code128, UPC, EAN (GS1 ready)
	Stacked	PDF417, Code16K, RSS Family
	Matrixcode	Datamatrix, QRcode, microQR, MaxiCode, Dot Code, Aztec Code, Han Xin Code, MicroPDF417 and many more
Drawing capabilities	Logo image types	HPGL, PLT, DXF, DWG, AI, BMP, JPG, TIF, GIF, PNG
	Draws	Vector optimization and graphical adjustments
	Filling	Single, cross, triple lines filling, advanced spiral and pocketing with Marking preview
	Array	Grid array capabilities for IC marking
Automation	Mode	Stand-Alone, Master-Slave Ethernet
	Scrip	step and repeat with different control objects (Wait, Timer, ...)
	Mechanical Axis	motion control for driving 4 external step motor : x, y, z and Rotary/indexer axis
	Programmable Interface	ActiveX, Scrip, Sequence
	Communication protocols	Ethernet, RS232



LASER MARKING PRODUCTS



LASER MARKING PRODUCTS

AREX PULSED



The AREX Series is a multi-functional, all inclusive, line of fiber laser markers dedicated to direct part marking in the Automotive, Electronics, and precision mechanics industry.

Thanks to its small head dimensions, to the flexible marking platform and the advanced software features, AREX laser marker, provides a flexible, reliable, cost effective solution for permanent and indelible high quality marking directly on your production line.

AREX Series includes 5 different fiber laser sources, spanning power and pulse width ranges on one single unified platform.

Arex series offers more than just a laser marker. Arex's Embedded Marking Controller simplifies setup, configuration and management of single or multiple laser markers, both in stand-alone or in master-slave configuration.

Arex Series: a complete and powerful laser marker solution ideally suited for any industrial part marking.

FEATURES & BENEFITS

Quick installation and setup

AREX design and configuration dramatically simplifies and speeds up machine design and system integration.

- Embedded Marking Controller (EMC) with LIGHTER Suite ensures quick and easy installation, setup, control and system diagnostics even from remote via Ethernet TCP/IP
- Ultra compact Scan-head (112x298x90mm) save space and costs during installation and setup
- Built-in step motors controller, totally integrated in software editor, dramatically simplifies integration of rotary indexers, x-y tables and z axis
- Front panel USB for quick and easy system update and layout transfer

Flexible programming and control

LIGHTER Suite, with its Intuitive and easy-to-learn interface, simplifies the development of a complete and cost effective Laser Marking Station for OEM and Machine builders.

AREX is thought to be used in both a STAND ALONE MODE with built-in control and software resources, and in a MASTER-SLAVE mode with a with supervising computer for advanced network-oriented Laser Marking Applications.

Main built-in features are:

- Advanced Graphical Layout
- Local and Remote laser diagnostic
- Local and Remote I/O & axis control
- Local and Remote laser test & setup
- Local and Remote ActiveX
- Ethernet protocol for easy integration in PLC and industrial environments
- Marking On Fly capabilities

APPLICATIONS

- High contrast DPM (Direct Part Marking)
- Laser Engraving
- Label Replacement
- Branding

MATERIALS

- **Metals:** Stainless steel, high-grade steel, steel, Carbon steel, Copper, Iron, ferrous metals, Magnesium, Aluminum, Brass, Gold, Silver, Platinum, Titanium ...
- **Plastic:** Polycarbonate (PC) Polysulfone (PSU), Polyphenylene sulfide (PPS), Polystyrene (PC), Acrylonitrile Butadiene Styrene (ABS), Polyethylene terephthalate (PET) ...
- **Ceramics:** Aluminum Oxide (Al₂O₃), Zirconium Oxide (ZrO₂), Aluminum Titanate (Al₂TiO₅), Silicon Carbide (SiC/SSiC), Zirconium Oxide (ZrO₂)

INDUSTRIES

- Automotive
- Industrial electronics,
- Tool making
- High precision mechanics & manufacturing
- Visual communication,
- Medical/surgical tools and implants



AREX M.O.P.A.



AREX 20 MW is based on the proprietary MULTIWAVE M.O.P.A. fiber laser technology designed for maximum control of laser emission.

FEATURES & BENEFITS

High flexibility and marking repeatability

All the features for AREX family, with an higher level of performances aimed to precision marking. Additional features:

- Linear power range from 0.1W to full power for precise marking even on sensitive materials
- Pulswidth adjustment from 4 ns to 250 ns for best process optimization and repeatability
- High repetition rate up to 500KHz for faster marking and accurate texturing
- High peak Power for extended process capability.
- Standard Datalogic I/O interface.

APPLICATIONS

- High contrast DPM (Direct Part Marking)
- Annealing
- High quality Branding
- Texturing
- Laser processing

INDUSTRIES

- Automotive
- Aviation & aerospace
- Industrial electronics
- Mobile & semicon electronics
- Precision mechanics,
- Medical/surgical tools and implants

PROCESSES

- High precision annealing & Color Marking on metals :
- 'Black Marking' on anodized aluminum
- High quality appearance, aesthetical marking on plastic

MATERIALS

- **Metals:** Stainless steel, high-grade steel, steel, Carbon steel, Copper, Iron, ferrous metals, Magnesium, Aluminum, Brass, Gold, Silver, Platinum, Titanium ...
- **Plastic:** Polycarbonate (PC) Polysulfone (PSU), Polyphenylene sulfide (PPS), Polystyrene (PC), Acrylonitrile Butadiene Styrene (ABS), Polyethylene terephthalate (PET) ...
- **Ceramics:** Aluminum Oxide (Al₂O₃), Zirconium Oxide (ZrO₂), Aluminum Titanate (Al₂TiO₅), Silicon Carbide (SiC/SSiC), Zirconium Oxide (ZrO₂)

PARAMETER		AREX 10	AREX 20	AREX 30	AREX 50	AREX 20MW
Nominal power	W	>10	>20	30	50	>20
Pulse energy (max)	mJ	0,5	1,0	1,0	1,0	0,6
Peak power (max)	kW	5	10	11	10	12
Modulation	kHz	20 ÷ 100		30 ÷ 100	50 ÷ 100	20 ÷ 100
Laser source		Pulsed Fiber Laser				M.O.P.A. Fiber Laser
Pulswidth (Typ)	ns	FIXED: 100				Adj: 4, 8, 12, 30, 50, 100, 200, 250
Wavelength	nm	1050 ÷ 1080				
Marking capabilities		Static, Rotary axis, On the fly (marking in motion)				
Integration		Up to 4 mechanical axis driving capabilities (step motors) Up to 10 digital inputs and 10 digital output fully programmable dedicated connectors Encoder and Photocell				
Aiming & Focus Beam		Semiconductor laser @ 635nm				
Protection rating		Head: IP54; Controller: IP 21				
Cooling		Air cooled				
Power Supply		100/240 VAC – 50/60 Hz – 400 W (MAX)				
Head Dimensions & Weight		90mm x 112mm x 300mm – 3 kg				
Controller Dimensions & Weight		111mm x 430 mm x 370 mm - 16 kg				

LASER MARKING PRODUCTS

UNIQT[™]



UniQ[™] marker is a revolutionary and innovative approach to Fiber Laser Marking.

UniQ[™] fiber laser marker represent the perfect combination of a high performance fiber laser into a innovative, ultra-compact housing designed to provide an effective solution to the recent request of shorter, smaller production lines, in order to reduce footprint and floor area consumption.

Thanks to its advanced internal design, UniQ[™] laser marker does not need any low-ip grade external cabinet, controller or power supply, and is totally free from delivery fiber constraints such as fiber length and fiber bending limitations.

The IP54 rated innovative housing guarantees maximum protection even in harsh factory environments and industrial applications.

UniQ[™] laser marker works seamless with Datalogic's Lighter Suite, a powerful, quick and intuitive marking software, and is fully compatible with the latest Datalogic I/O interfaces.

FEATURES & BENEFITS

- Powerful 15W fiber laser source
- All-in-one, Fully integrated ultra-compact device
- Rugged IP54 rated housing
- All included: No external controller, no external power supply needed
- No fiber delivery constraints
- Built-in second generation EMC (Embedded Marking Controller)
- Great Money Vs Watt ratio
- Powered by Lighter software Suite

MAIN APPLICATIONS

FACTORY AUTOMATION

- **Automotive**
 - High Contrast DPM for traceability, quality control, testing & sorting.
 - Label replacement, inkjet replacement.
 - High engraving depth for END -OF-LIFE traceability
- **Industrial Electronics**
 - High contrast marking on additivated plastic materials
 - High speed coding and branding on industrial electronic devices

Other

- **Medical & surgical tools**
 - Contactless and Clean Direct Marking Process for Branding & Personalization
 - Instant permanent marking: no drying time, no post processing, no solvent or additive
- **Precision Mechanics**
 - high precision marking with no mechanical stresses
 - Clear and precise annealing even on very small surface



PARAMETER		UNIQT
Wavelength	nm	1060 – 1080 nm
Nominal Power	W	15 W
Repetition Rate Range	kHz	15 – 100 kHz
Pulsewidth	Typ	120 nsec
Pulse Energy	mJ	0.75 mJ
Peak power	kW	10 kw
Marking capabilities		Standing, Rotary axis, On the fly (marking in motion)
integration		Up to 4 mechanical axis driving capabilities (stepper motor) Up to 10 digital inputs and 10 digital output fully programmable dedicated connectors for Datalogic's Encoder and Photocell
Interface		Ethernet, RS 232, 4x USB
Aiming & Focus Beam		Class II Semiconductor laser @ 635 nm
Power Supply		100/240 VAC – 50/60 Hz
Cooling System		integrated air
Temperature Range	°C	5 to 40

VLASE SERIES: IR, GREEN, UV



VLASE SERIES now combines state-of-the-art YVO4 Solid State laser sources with the high flexibility and easy setup of the 'ONE.RACK' embedded controller, providing machine builders, system integrators and end users a unified I/O interface for all three main laser marking technologies as well as only one control unit footprint and design. The high performance embedded controller provides easy operation in stand-alone configuration as well as sophisticated integration in master-slave configuration.

FEATURES & BENEFITS

- Compact, high performance laser resonator
- Detachable resonator & optical fiber
- High Peak power up to 60 kW
- Infrared, Green and UV on same platform
- Build-in embedded controller
- Ethernet, RS232, 4x USB ports
- Dedicated I/O for photocells and encoders
- 4 axis embedded controller

MAIN APPLICATIONS

FACTORY AUTOMATION

▪ Automotive

Coating removal and paint stripping for NIGHT & DAY application

High Contrast DPM for traceability, quality control, testing & sorting on high reflectivity materials.

▪ Electronics

DPM for traceability to thermal sensitive, like silicon wafers, WLCSP, memory cards, ICs or high reflectivity materials like copper, gold and silver

Branding and high resolution product identification

Other

▪ Healthcare

Branding and high resolution product identification
DPM for traceability, quality control, testing & sorting, quality selection.

High quality marking on highly stable material for medical implants

▪ High Precision Machining

Branding and high resolution product identification

DPM for traceability, quality control, testing & sorting, wip track and control, quality selection



PARAMETER	VLASE IR 10	VLASE IR 20	VLASE GREEN 10	VLASE UV 3
Wavelength [nm]	1064	1064	532	355
Nominal Power [W]	10	20	10	3
Repetition Rate Range [KHz]	10 ÷ 100	20 ÷ 200	20 ÷ 100	20 ÷ 80
Pulse Width [ns]	15@10KHz	8@20KHz	10@50KHz	8@25KHz
Max Pulse Energy [mJ]	0.48@10kHz	0.55@20KHz	0.31@20KHz	0.12@30KHz
Peak power [kW]	32@10KHz	65@20KHz	28@20KHz	14@25KHz
Marking capabilities	Standing, Rotary axis, On the fly (marking in motion)			
integration	Up to 4 mechanical axis driving capabilities (stepper motor)			
Interface	Up to 10 digital inputs and 10 digital output fully programmable dedicated connectors Encoder and Photocell			
Interface	Ethernet, RS 232, USB			
Optical Fiber	Detachable – 3 meters standard- 5 meters OPT			
Aiming Beam	Class II Semiconductor laser @ 635 nm			
Power Supply	100- 240 VAC 50/60Hz – 600 W max			
Cooling System	Air cooled			
Temperature Range	5°C to 40°C (41°F to 104°F)			

LASER MARKING PRODUCTS

ULYXE



The Ulyxe product line provides ideal laser marking solutions for both stand-alone applications and industrial production lines.

The Ulyxe integrates a 6.5W DPSS laser marking system providing a cost effective and innovative design. With the best price/performance for plastics and metals, Ulyxe is the first choice in laser marking systems.

FEATURES & BENEFITS

- Air-cooled, reduced footprint ultra-compact design
- All-in-one design: scanning head, power driver & control electronics, marking controller, diagnostic and software suite
- Embedded, visible aiming beam and focus beam for fast and easy focus finding and simplified marking operations setup
- User-friendly touch screen LCD display for monitoring and controlling laser status and functions
- Patented, high efficiency, laser resonator design
- Best price to performance ratio on the market

MAIN APPLICATIONS

MANUAL OR LOW THROUGHPUT APPLICATIONS

- **Automotive**
Label marking, paint stripping & coating removal
- **Electronics**
Branding and coding of thermoplastic polymers for electronics industry
- **Healthcare**
Branding and high resolution for medical devices and traceability for implants
- **Tool industry**
Branding, personalization of high quality tools.

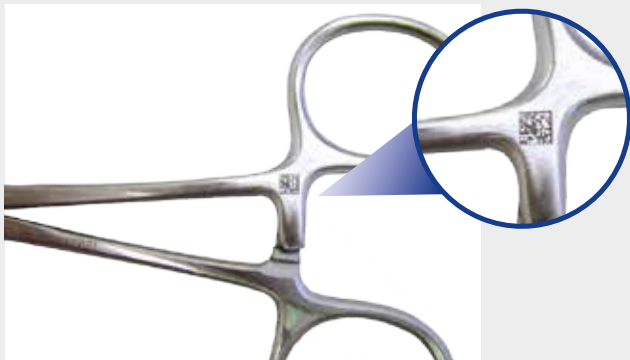

PARAMETER		ULYXE	ULYXE PL	ULYXE IMARK
Nominal average power	W	6	6	6
Wavelength	nm	1064	1064	1064
Repetition Rate	KHz	10 – 100	10 – 100	10 – 100
Marking capabilities		Static		Static, Rotary axis, On the fly (marking in motion)
Integration		Up to 4 mechanical axis driving capabilities (stepper motor)		Up to 4 digital inputs and 4 digital outputs fully programmable Up to 10 digital inputs and 10 digital output fully programmable dedicated connectors Encoder and Photocell
Aiming & Focus Beam		Class II Semiconductor laser @ 635 nm		
Cooling system		Air cooled		
Display		YES, touch screen	NO, OPTIONAL	NO, OPTIONAL
Power Supply		24 VDC – 300 W MAX		
Operating Temperature Range	C°	10 to 35		

EOX SERIES



EOX is a family of CO₂ Laser Markers for laser coding and marking applications. EOX offers high quality permanent marking on a wide range of materials like paper, carton, wood, plastics, painted or coated metals, and many other organic materials. Combining excellent laser beam quality and an advanced control unit, EOX is suitable for accurate industrial traceability, branding and coding applications. Based on the Embedded Marking Controller Platform (EMC), flexible 'Stand Alone' or 'Master – Slave' control modes and provides axis control as well as dedicated photocell / encoder ports for marking-on-the-fly (MOF). Thanks to its low operating cost, long lifetime and minimal maintenance, EOX provides a reliable and clean technology for industrial marking and coding applications.

FEATURES & BENEFITS

- Air-cooled, reduced footprint
- All-in-one design: scanning head, power & control electronics, marking controller, diagnostics and software suite
- Embedded visible aiming beam and focus beam for fast and easy focus setup and marking operation
- High resolution marking

MAIN APPLICATIONS

- **General Marking:**
Label marking, paint stripping & coating removal, kiss-marking and perforating labels
- **Electronics**
PCB marking and coding, ceramic component marking, alumina marking
- **Healthcare**
Branding and coding containers
- **Food**
Direct, high contrast marking on food (cheese, bread, eggs, fruits, vegetables ...)
- **Packaging**
Marking coated paper, inked paperboards, film cutting and perforating



PARAMETER		EOX 10	EOX 30
Nominal average power	W	10	30
Wavelength	nm	10600	
Marking capabilities		Static, Rotary axis, On the fly (marking in motion)	
Integration		Up to 4 mechanical axis driving capabilities (stepper motor) Up to 10 digital inputs and 10 digital output fully programmable dedicated connectors Encoder and Photocell to 75mt/min and 12.000 pcs/hour	
Aiming & Focus beam		Class II Semiconductor laser @ 635 nm	
Cooling system		Air cooled	
Resonator dimensions & weight		180x185x634 mm	kg 17
Controller dimensions & weight		-	437x94x333 mm kg 9
Power Supply		100 – 240 VAC 50/ 60 Hz	
Operating Temperature Range	°C	10 to 35	



ACCESSORIES



ACCESSORIES

FUMES EXTRACTOR - LAS 160



Twin filtration system particles + activated carbon.

- Ultra compact specialty laser fumes extractor
- Max air flow 190 m3/h
- Adjustable air flow
- Dimensions 400x350x500 mm (WxDxH)

Suitable for:

- Metal Marking
- Wood, paper marking
- Rubber, Plastic marking

CODE	DESCRIPTION
985340035	FUMES EXTRACTOR

STARTER KIT FOR MARKING ON THE FLY



Ready to use rotary encoder and photocell for Marking on the fly application, complete with dedicate wiring for AREX, UNIQ VLASE connections

KIT includes:

- ENCODER 5000 PPR - ENC58-S10 - 5000 -M12
- Photocell S51 -PA-5-B01-PK
- Selection of prismatic reflectors (48, 18x54, 51 x64 mm)
- Cable kit for direct connection with AREX, UNIQ, VLASE

CODE	DESCRIPTION
985330027	PF KIT ENCODER PHOTOCELL FOR MOF

CONTROL BOX



Ready to use remote pendant for UNIQ AREX VLASE.

- 2 meters cable
- Key & enable selectors
- START STOP push-buttons
- READY, BUSY, END, ALARM led signals
- Available also for ULYXE series

CODE	DESCRIPTION
985330031	CONTROL BOX STANDARD (AREX UNIQ VLASE)
985330001	ULYXE BASIC CONTROL BOX (ULYXE ONLY)

F-THETA LENS & ACCESSORIES

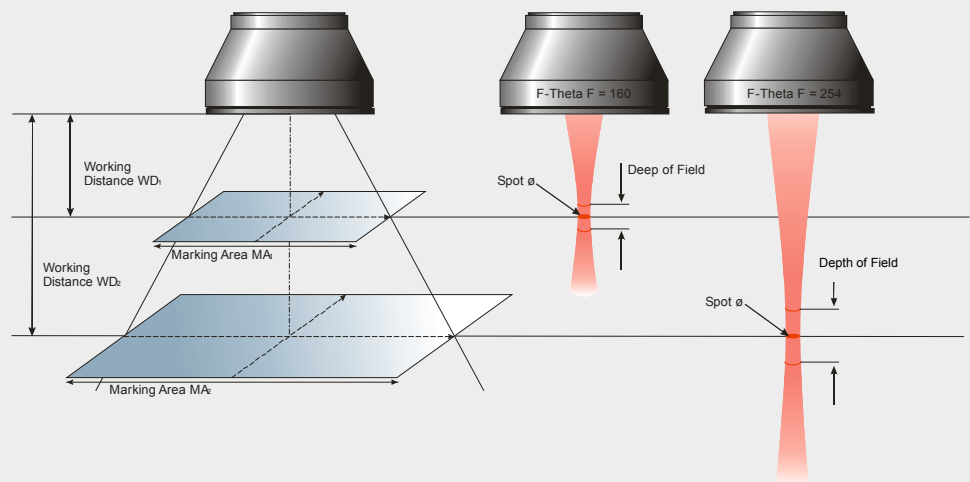

AREX & UNIQ FAMILY

F-THETA LENS	LENS CODE	MARKING AREA [MA]	PRECONFIGURED LASER MODEL		FIXING DISTANCE [FD]	WORKING DISTANCE [WD]	ESTIMATED SPOT DIAM (Typ)	LENS THREAD	ADAPTER CODE
			LASER	ORDER CODE					
F 100S	985300029	60 x 60	AREX 10	985180058	146	118	~ 40	M39x1.0	985300021
			AREX 20	985180059					
F 160S	985300011	100 x 100	UNIQ	986101010	197	183	~ 60	M39x1.0	985300021
			AREX 10	985180027					
			AREX 20	985180029					
			AREX 20 MW	985180048					
F 160L	985300012	100 x 100	AREX 30	985180063	212	176	~ 60	M85x1.0	985300022
			AREX 50	985180064					
F 254 S	985300013	140 x 140	UNIQ	986101020	300	280	~ 90	M39x1.0	985300021
			AREX 10	985180028					
			AREX 20	985180030					
			AREX 20 MW	985180049					
F 254L	985300018	180 x 180	UNIQ	986101030	367	296	~ 90	M85x1.0	985300031
			AREX 10	985180069					
			AREX 20	985180051					
		AREX 20 MW	985180066						
		170 x 170	AREX 30	985180052					
			AREX 50	985180055					
AREX 20	985180060								
F 330L	985300019	220 x 220	AREX 20 MW	985180067	471	388	~ 120	M85x1.0	985300022
			AREX 30	985180053					
		210 x 210	AREX 50	985180056					
			AREX 20	985180061					
F 420L	985300020	285 x 285	AREX 20 MW	985180068	575	494	~ 160	M85x1.0	985300022
			AREX 20	985180061					

VLASE AND ULYXE

F-THETA LENS	LENS CODE	MARKING AREA [MA]	PRECONFIGURED LASER MODEL		FIXING DISTANCE [FD]	WORKING DISTANCE [WD]	ESTIMATED SPOT DIAM (Typ)	LENS THREAD	ADAPTER CODE
			LASER	ORDER CODE					
F 103 T*	985300010	60 x 60	VLASE 3 UV	985110051	149	135	~ 25	M85x1,0	985300022
F 160S	985300011	100 x 100	ULYXE	985130001	197	183	~ 60	M39x1.0	985300021
			VLASE 10 IR	985110039					
			VLASE 15 IR	985110042					
			VLASE 20 IR	985110044					
F 160L	985300012	110 x 110	VLASE 10 IR	985110040	212	176	~ 60	M85x1.0	985300022
			VLASE 15 IR	985110043					
			VLASE 20 IR	985110045					
	985300003	VLASE 10 GREEN	985110062	~ 40					
	985300008	VLASE 3 UV	985110056	~ 35					
F 254 S	985300013	140 x 140	ULYXE	985130018	300	280	~ 90	M39x1.0	985300021
			VLASE 10 IR	985110052					
			VLASE 15 IR	985110053					
			VLASE 20 IR	985110054					
F 254L	985300018	180 x 180	VLASE 10 IR	985110057	367	296	~ 90	M85x1.0	985300031
			VLASE 15 IR	985110058					
			VLASE 20 IR	985110059					
			VLASE 10 GREEN	985110064					
F 330L	985300019	220 x 220	VLASE 20 IR	985110060	471	388	~ 120	M85x1.0	985300022
F 420L	985300020	285 x 285	VLASE 20 IR	985110061	575	494	~ 160	M85x1.0	985300022

NOTE: *Telecentric F-theta Lens

EOX

F-THETA LENS	LENS CODE	MARKING AREA [MA]	PRECONFIGURED LASER MODEL		FIXING DISTANCE [FD]	WORKING DISTANCE [WD]	ESTIMATED SPOT DIAM (Typ)	LENS THREAD	ADAPTER CODE
			LASER	ORDER CODE					
F 100 ZnSe	100	70 x 70	EOX 10	985140000		96	~ 250	~ 48	INCLUDED
			EOX 30	985140100					
F 100 ZnSe	200	140 x 140	EOX 10	985140014		196	~ 370	~ 48	INCLUDED
			EOX 30	985140012					

10600 nm ZINC SELENIDE CO2 F-THETA LENS

When handling optics, one should always wear gloves. This is especially true when working with zinc selenide, as it is a hazardous material. For your safety, please follow all proper precautions, including wearing gloves when handling these lenses and thoroughly washing your hands afterward



www.datalogic.com

Rev. 04, 02/2017



9C514600E